

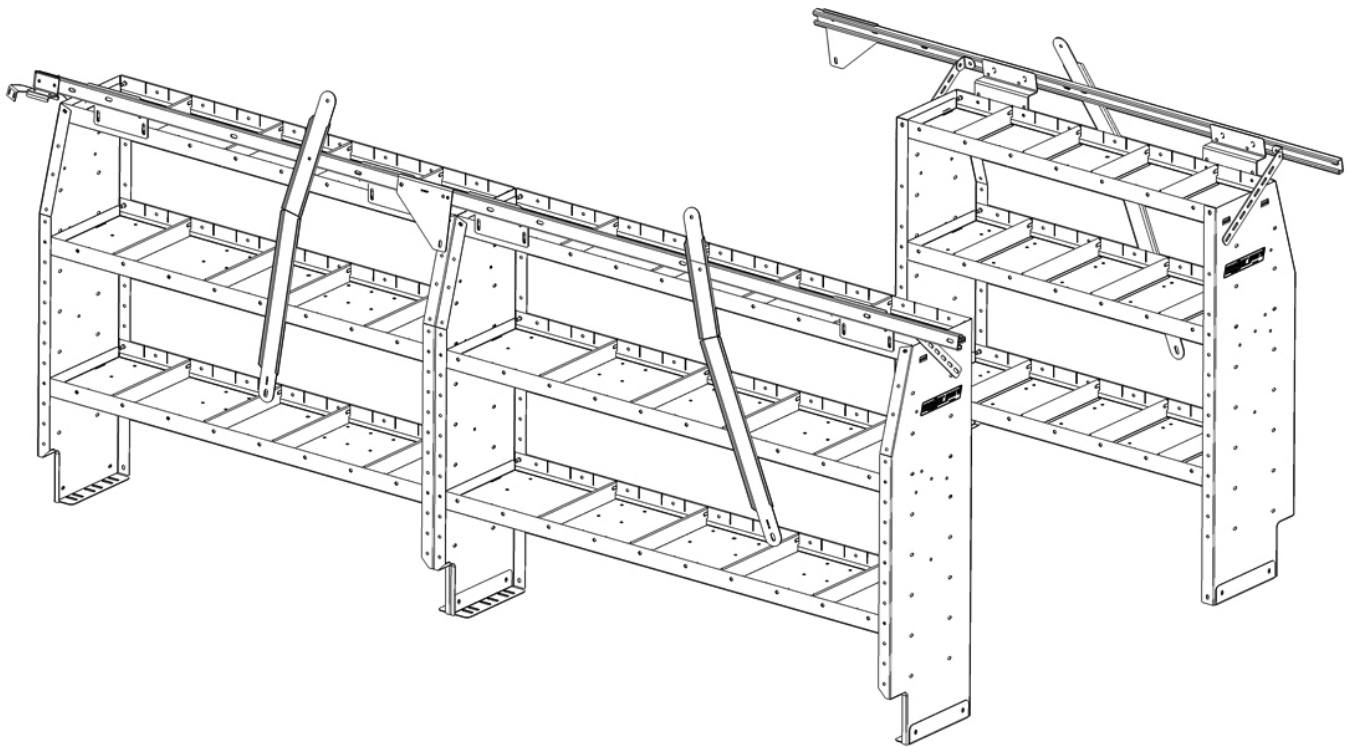

VAN STORAGE SOLUTIONS

**INSTALLATION INSTRUCTIONS for  
FORD TRANSIT LOW ROOF  
SHELVING MOUNTING KIT**



Weather Guard / WERNER CO.  
420 E. Terra Cotta Ave.  
Crystal Lake, IL 60014 USA

800-456-7865 (Toll Free)  
800-334-2981 (Fax)

Weather Guard / WERNER CO.  
9133 Leslie St. Unit 105  
Richmond Hill, ON L4B4N1

888-562-2251 (Toll Free)  
888-456-8460 (Fax)

**ATTENTION: PLEASE READ AND UNDERSTAND ALL INSTRUCTIONS AND WARNINGS BEFORE ASSEMBLING, INSTALLING OR USING THIS PRODUCT.**



## PLAN YOUR VAN (TIPS FOR FASTER INSTALLATION)

FOR ELECTRIC VEHICLES – Drilling into electrical wiring may damage vehicle systems and may cause bodily harm. This equipment should be installed by qualified personnel familiar with this type of vehicle and the hazards involved. To prevent damage to components underneath the floor, mainly the battery and high voltage system components, refer to your vehicle manufacturer’s instructions or the manufacturer’s website for more information."

- Follow these instructions to install your WEATHER GUARD® van shelving inside a Ford Transit mid or high roof van.
- Using these mounting brackets you will be able to install the van shelving using factory installed weld nuts and mounting holes.
- Take into consideration any REDZONE end panel mounting accessories to be used and the desired location. The shelves can be easily adjusted.

## HARDWARE KIT

Description	Quantity
Carriage Bolt Plate	16
1/4"-20 x 3/4" Bolt	18
5/16"-18 x 1" Carriage Bolt	16
1/4"-20 Nylon Lock Nut	12
5/16"-18 Nylon Lock Nut	16
1/4" Washer	29
3/8" Spacer	8
3/4" Spacer	8
Blind Fastener Install Tool	1
1/4"-20 x 2-1/4" Bolt	8
5/16" Washer	22
M8-1.25 x 35mm Socket Cap Screw	6
1/4-20 Blind Fastener	8
1/4-20 x 2-1/4" Bolt	1
1/3-20 x 5/8" Button Head Cap Screw	11

## TOOLS REQUIRED

5/32" Allen Wrench	Electric drill
7/16" Socket	Punch
7/16" Wrench	Hammer
1/2" Socket	1/4" drill bit
1/2" Wrench	3/8" drill bit
9/16" Wrench	1/2" drill bit
Level	Torque wrench
Marker	1" hole saw

## CAUTION

Be safe—always wear protective eyewear to keep debris out of your eyes when installing WEATHER GUARD® van products.

## PARTS LIST

### 975101-3-01 130" WB Low Roof Transit

Description	Quantity
Front Bracket Upper	1
Front Bracket Rear	1
Mid Bracket	2
Vertical Strap Front	1
Vertical Strap Rear	2
Shelf Bracket	6
Rear Mounting Channel (51.375")	2
Front Mounting Channel (52.5")	1

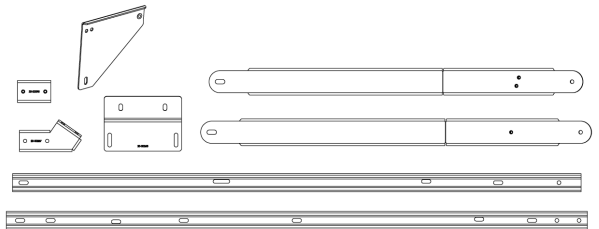

### 975102-3-01 148" WB Low Roof Transit

Description	Quantity
Front Bracket Upper	1
Front Bracket Rear	1
Mid Bracket	2
Vertical Strap Front	1
Vertical Strap Rear	2
Shelf Bracket	6
Rear Mounting Channel (68.925")	2
Front Mounting Channel (52.5")	1

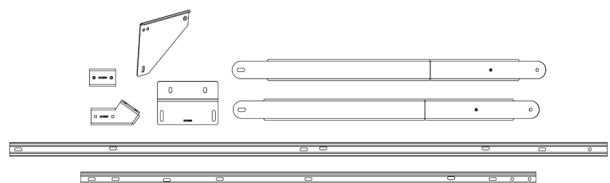

\* Images not to scale.

## MOUNTING KIT ASSEMBLY AND INSTALLATION INSTRUCTIONS

- The mounting channels will bolt to the upper inside wall and to Vertical Straps using a combination of factory installed weld nuts and blind fasteners.
- Front mounting channel (driver side) is common across all Transit models.
- There are two identical rear mounting straps in the kit and only one front mounting strap.
- The Weather Guard Van Installation Kit is compatible with OEM interior trim kit. Remove upper row of panels prior to installation of the mounting channels.

**STEP 1.** Mount Front and Rear Vertical Straps to factory installed weld nuts using M8-1.25 x 35mm socket cap screws. Passenger side rear mirrors the driver side rear section. Torque to 20 ft-lbs using a 5mm Allen wrench.

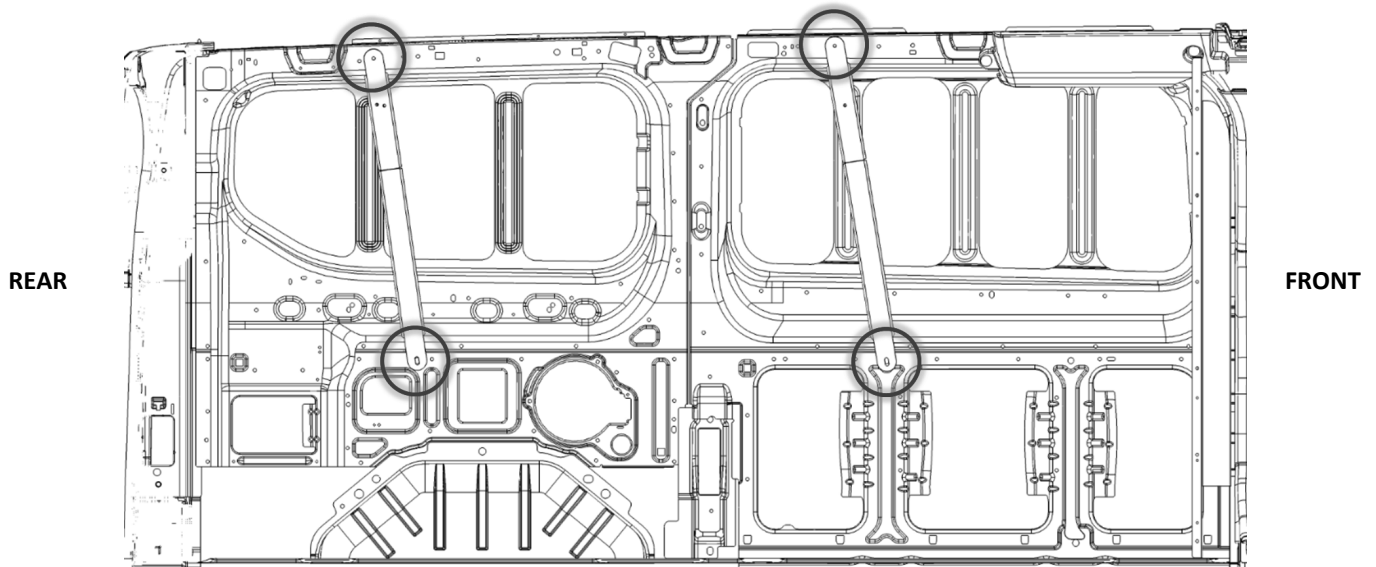

130" WHEELBASE

**NOTE:** The rear mounting straps have two weldnuts on the upper part of the strap.

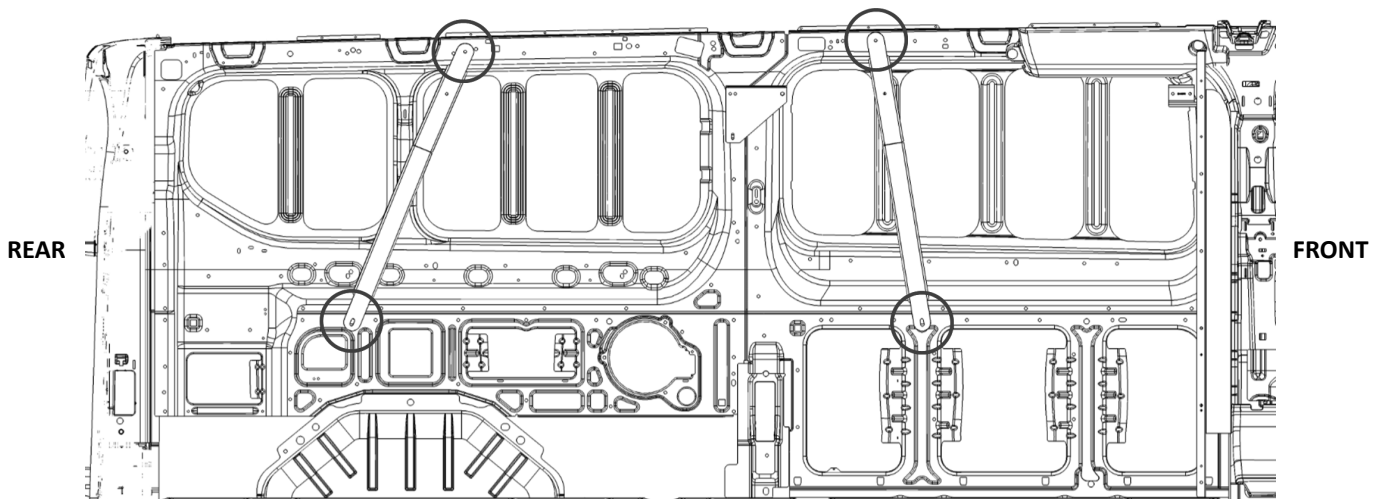

148" WHEELBASE

**NOTE:** The rear mounting straps are longer than the front mounting strap.

## MOUNTING KIT ASSEMBLY AND INSTALLATION INSTRUCTIONS

- STEP 2.** Install six 1/4-20 Blind Fasteners on pre-existing holes shown below. Passenger side mirrors driver side. 148" wheelbase vehicles will have pre-existing holes on the same location on the C-pillars and the rear of the vehicle.

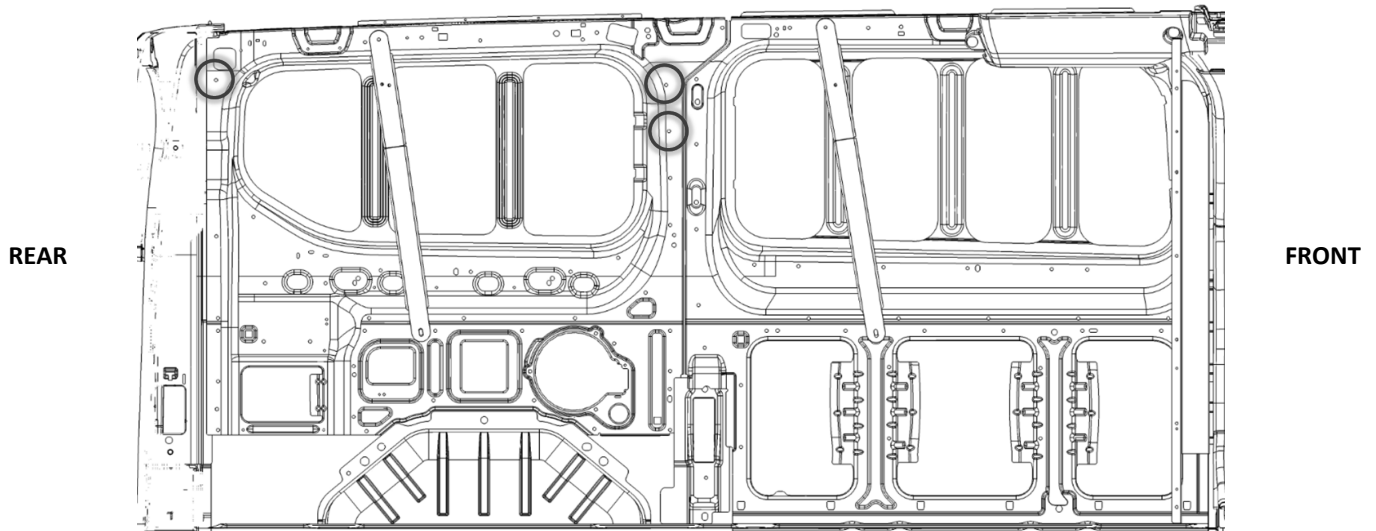

130" WHEELBASE SHOWN

Use 13mm socket (M8)  
or 7/16" socket (1/4-20)

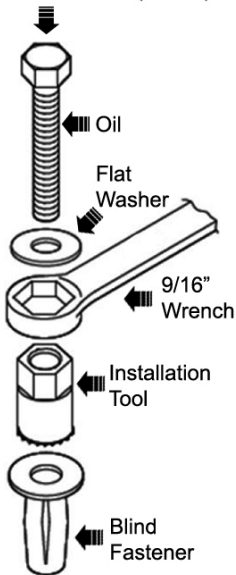

### INSTALLATION PROCEDURE USING BLIND FASTENERS

Place a drop of oil on the M8-1.25 x 55mm or 1/4-20 x bolt before assembling as shown on left.

Place the Blind Fastener in the hole and use a 13mm when installing M8 Blind Fastener or 7/16" socket when installing 1/4-20 Blind Fastener and driver to tighten the bolt until the Blind Fastener is fully seated.

When setting the bolt, it will start out tight. As the Blind Fastener "bulbs" out it will get easier, until it bottoms out of sets.

Make sure the Blind Fastener and the installation tool do not slip during the installation.

- Optional.** For vans equipped with OEM interior panels, remove the mounting channel, install M8 bolts flush to van wall. Place the interior panels over the bolts by installing OEM plastic fasteners on upper corners to hold them in place. Firmly press where the bolt heads are located to indent the OEM panels. Remove the panels and make 1/2" holes on marked points. Remove the M8 bolts. Reinstall OEM panels.

## MOUNTING KIT ASSEMBLY AND INSTALLATION INSTRUCTIONS

- STEP 3.** Install mid bracket using a 1/4-20 x 5/8" button head screw on the lower part of the bracket marked **A**. Align the rear-most hole **B** on the upper part of the bracket to the blind fastener installed in **STEP 2**.

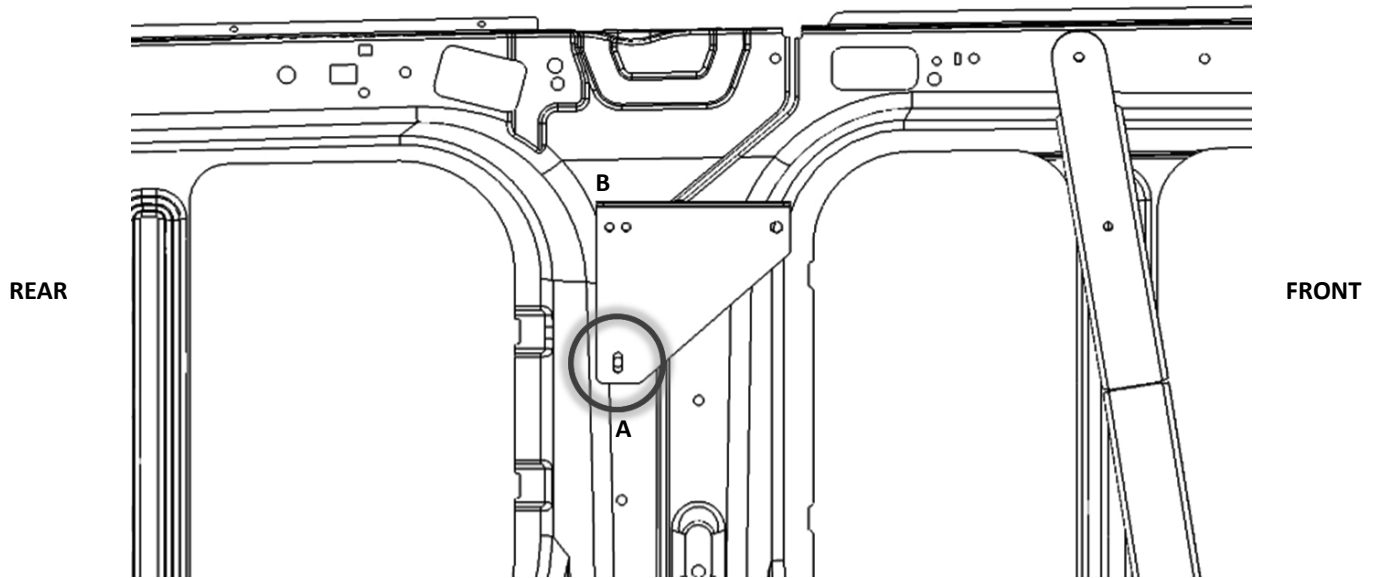

130" WHEELBASE DRIVER SIDE

- STEP 4.** Repeat the same process on the passenger side of the vehicle. The triangulated end of the mid bracket will now face the rear of the vehicle. The upper part of the bracket will still align to the rear-most hole **A**.

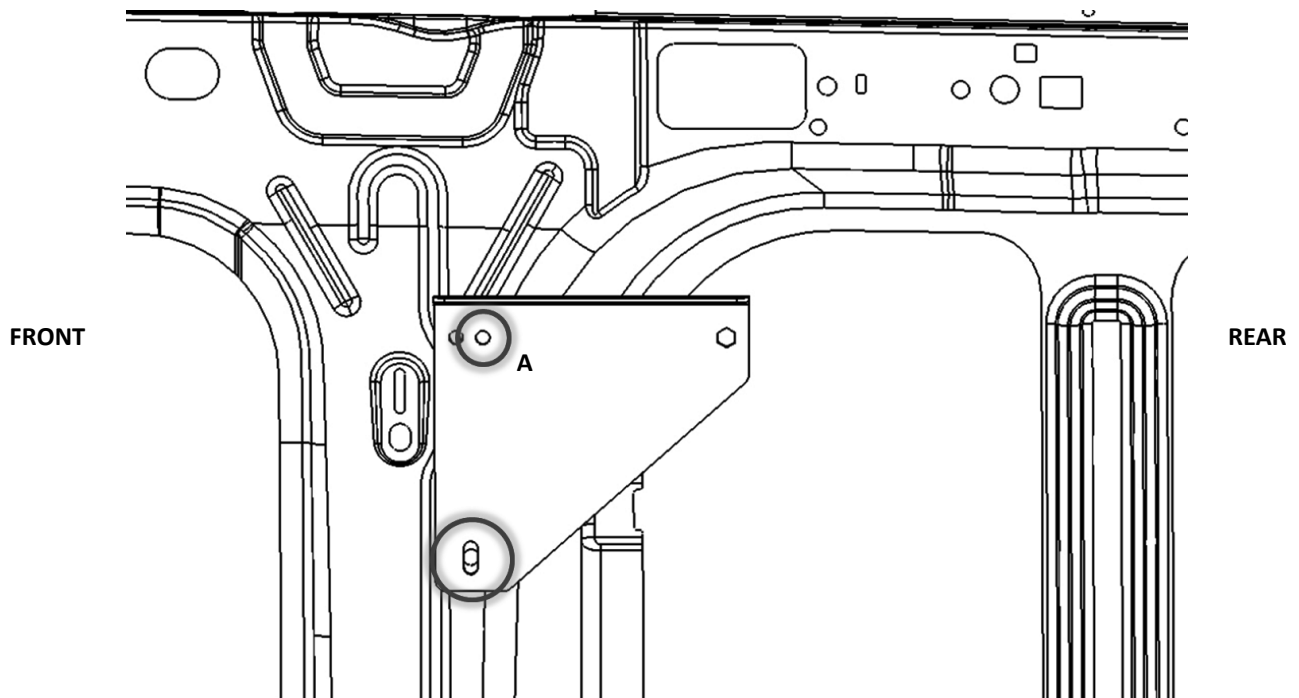

148" WHEELBASE PASSENGER SIDE

## MOUNTING KIT ASSEMBLY AND INSTALLATION INSTRUCTIONS

- STEP 5.** Install the rear mounting channel using three 1/4-20 x 5/8" button head screws on points shown below. The hole **A** on the mounting channel will need to be aligned with hole **B** in **STEP 3**. 130" wheelbase has two weldnuts on the rear mounting straps. Use the rear-most weldnut on both driver and passenger side. Torque to 80 in-lbs using a 5/32" Allen wrench. Torque the lower 1/4-20 x 3/4" bolt to 76 in-lbs.

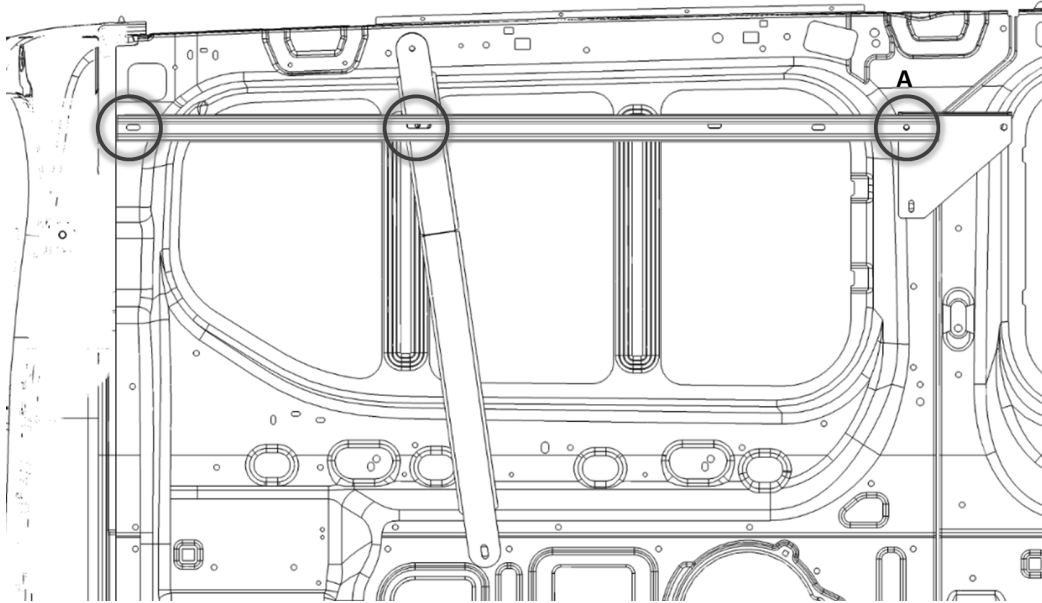

130" WHEELBASE DRIVER SIDE

- STEP 6.** Assemble the front bracket using two 1/4-20 x 3/4" bolts through **A** and attach to the front of the front mounting through **B**. Do not torque them down at this time.

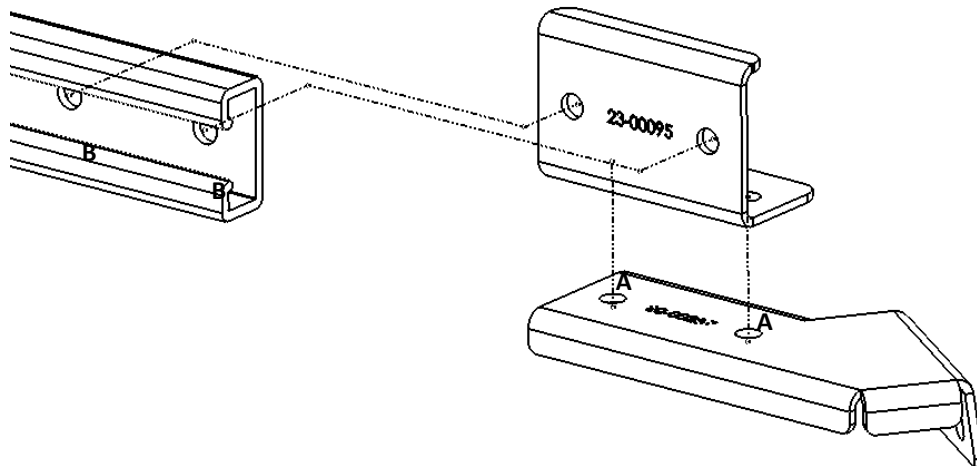

## MOUNTING KIT ASSEMBLY AND INSTALLATION INSTRUCTIONS

- STEP 7.** Attach the front bracket/front mounting channel assembly to the front of the mid bracket and front mounting strap using two 1/4-20 x 5/8" button head screws. Do not torque them down at this time.

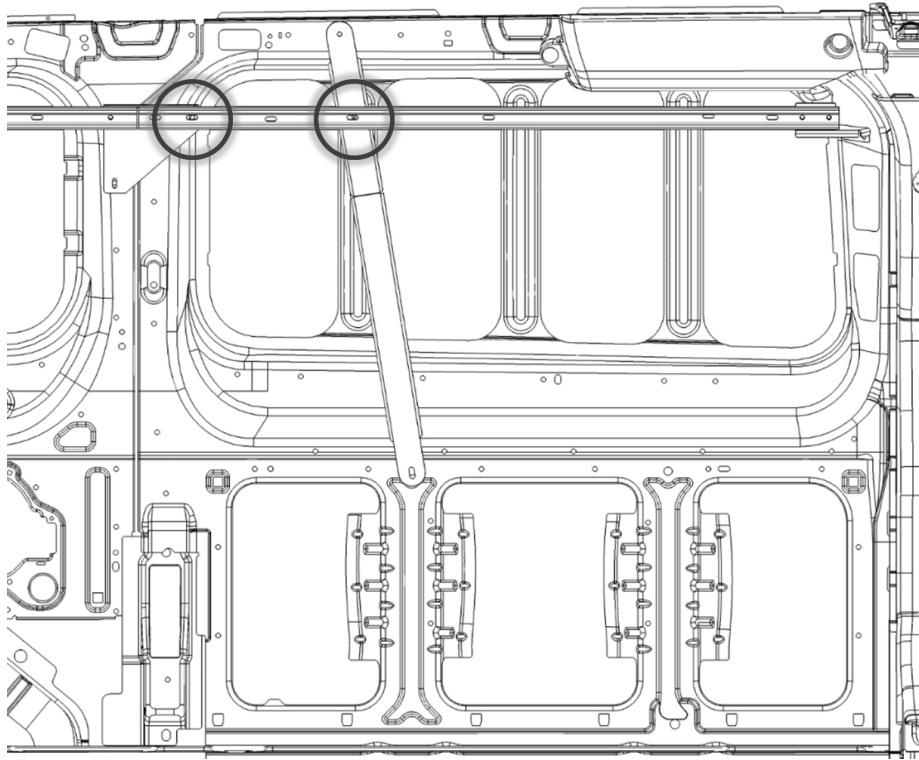

- STEP 8.** Level the front mounting channel and mark in the center of the two vertical slots **A** on the front bracket.

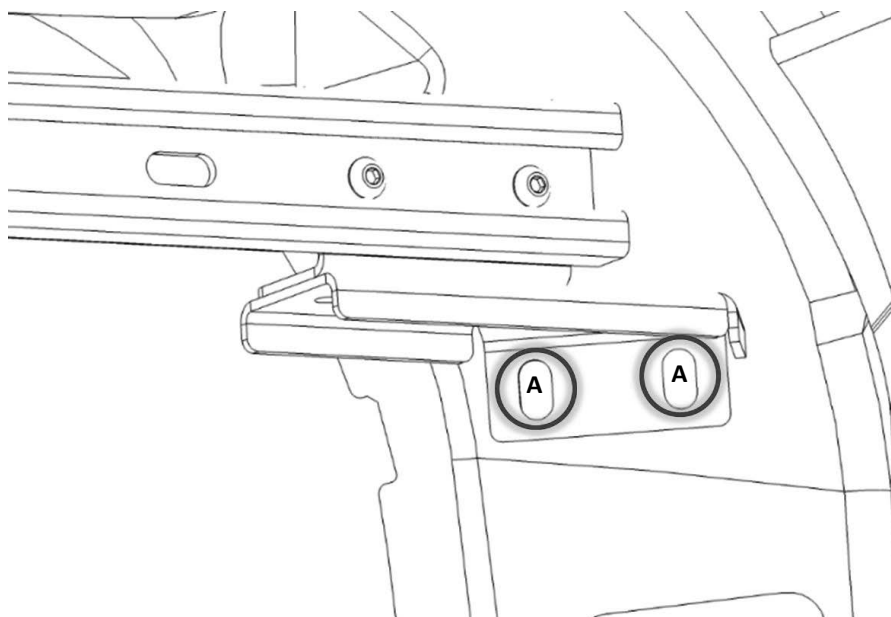

## MOUNTING KIT ASSEMBLY AND INSTALLATION INSTRUCTIONS

- STEP 9.** Remove the 1/4-20 x 5/8" button head screw **A** from the front mounting strap and allow the front channel to rotate clockwise about **B** to expose the marked points in **STEP 7**. Install two 1/4-20 blind fasteners.

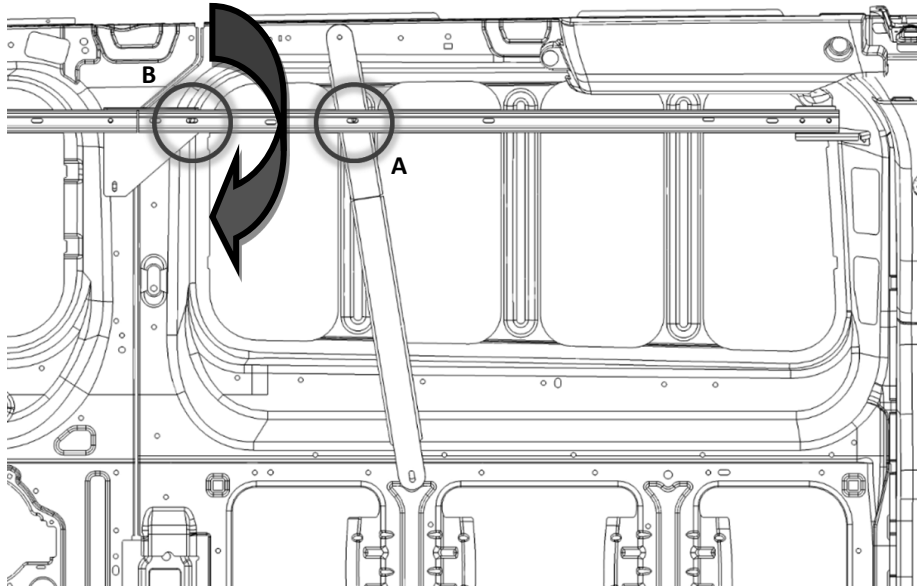

- STEP 10.** Level the front mounting channel and reinstall 1/4-20 x 5/8" button head screw on the mounting strap **A**. Attach the front bracket to the blind fasteners **B** using two 1/4-20 x 3/4" bolts. Make sure the channel is leveled and tighten all hardware. Torque the 1/4-20 x 5/8" button head screws to 80 in-lbs using a 5/32" Allen wrench. Torque the 1/4-20 x 3/4" bolt to 76 in-lbs using a 7/16" socket.

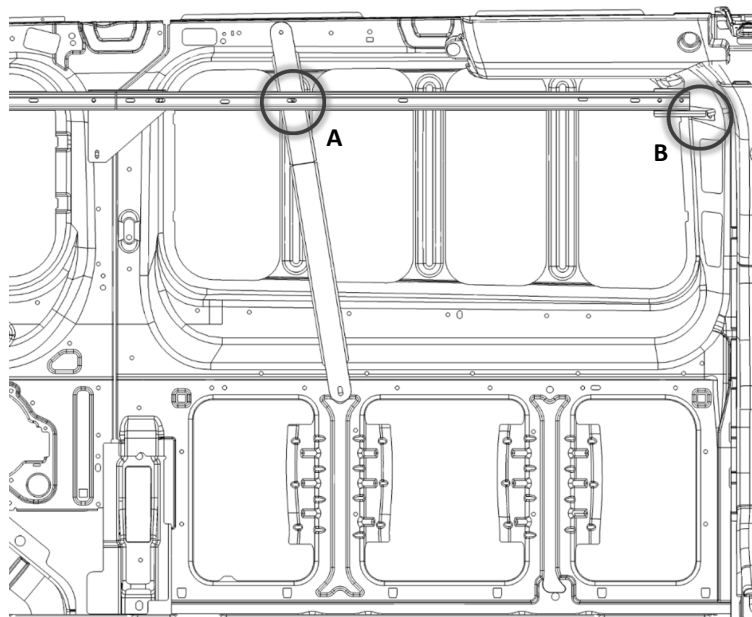



## MOUNTING KIT ASSEMBLY AND INSTALLATION INSTRUCTIONS

- STEP 11.** Position pre-assembled (minus mounting feet) shelving inside the van. Plan out positioning of the shelves and accessories relative to bulkhead and wheel well.



- STEP 12** Assemble two mounting plates to the back of the top shelf lip on outer-most position shown below using two 1/4-20 x 3/4" bolts, washers, and nylon lock nuts. Do not torque them down at this point.

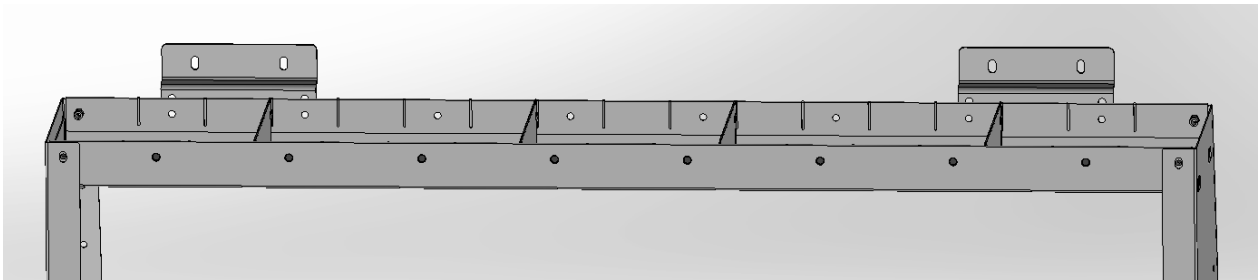

## MOUNTING KIT ASSEMBLY AND INSTALLATION INSTRUCTIONS

- STEP 13.** Position the carriage bolt plate such that you can read the word "TOP" and insert 5/16-18 carriage bolt from the bottom of the plate. Note: using a piece of masking tape (or equivalent) on back of the plate to lightly hold the carriage bolt to the plate may allow easier installation. You will need four plates per shelving unit plus two for each side (driver/passenger) for the end straps.



- STEP 14.** Insert the carriage bolt/plate assemblies through the mounting channel and rotate 90 degrees clockwise. Ten will be used on driver side and six will be used on passenger side when installing standard configuration of two and one shelving for driver side and passenger side, respectively. Note: 148" EXT Vans use three shelves on the driver side, thus, will require 14 carriage bolts/plates on driver side.

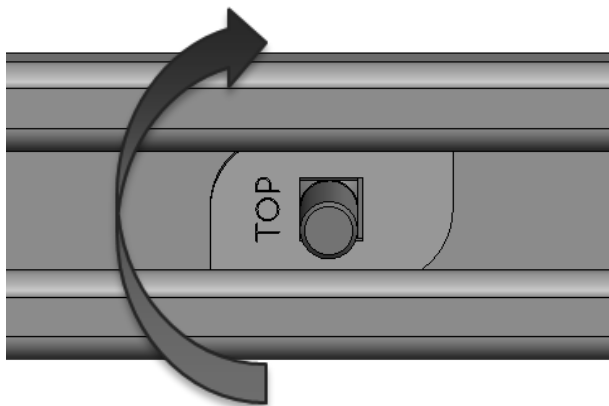

## MOUNTING KIT ASSEMBLY AND INSTALLATION INSTRUCTIONS

- STEP 15.** Position the shelves and carriage bolts/plates in desired location and fasten the shelves to the carriage bolt/plate using 5/16-18 nylon lock nuts and washers using 1/2" socket. Fine tune the position and alignment of the shelves in desired location. Torque them down to 13 ft-lbs.



- STEP 16.** Place the mounting foot to the inside of the end panel and mark drilling points. Use a spacer when mounting on uneven surface as shown below. Use a 1" hole saw if the van is equipped with floor mats. Use a 1/4" drill bit for pilot and 3/8" drill for 1/4-20 blind fasteners. Install 1/4-20 blind fasteners on the floor. Refer to blind fastener instruction on page 5. **Always be sure to make sure you won't be damaging wiring, gas lines, or other critical vehicle systems when drilling.**

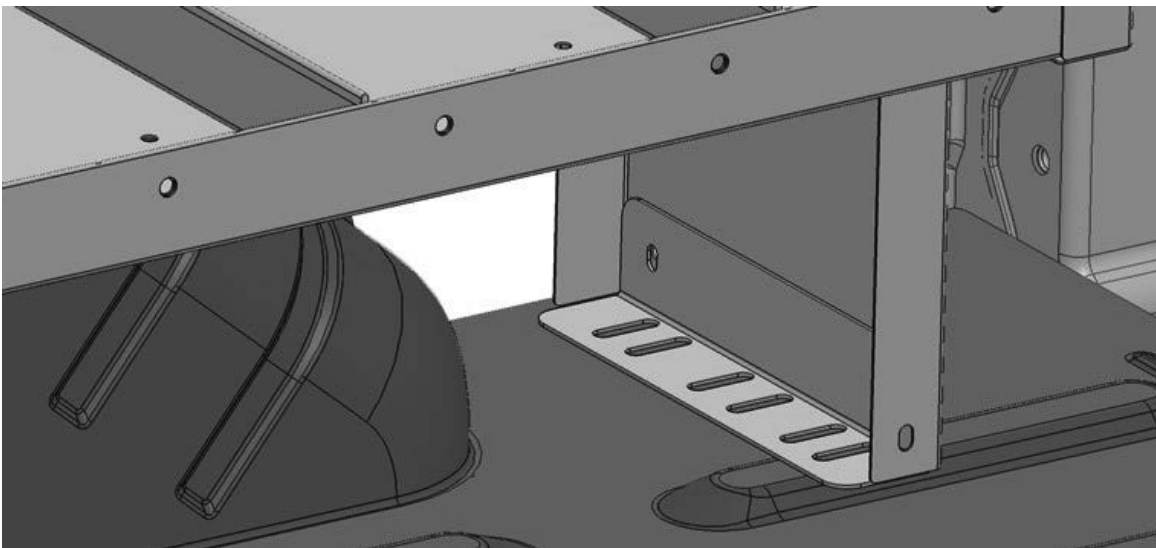

## MOUNTING KIT ASSEMBLY AND INSTALLATION INSTRUCTIONS

**STEP 17.** Slip the mounting foot from the other side of the end panel and install using 1/4-20 x 3/4" bolts, washers, and nylon lock nuts. Install to floor blind fasteners using 1/4-20 x 1-1/2" bolts. Repeat steps 11 and 12 until all mounting feet are installed. Note that you only need to use one mounting foot where the driver side shelves join.



**STEP 18.** Torque down the 1/4-20 x 3/4" bolts, washers, and nylon lock nuts installed in **STEP 7** to 76 in-lbs.



## MOUNTING KIT ASSEMBLY AND INSTALLATION INSTRUCTIONS

- STEP 19.** Loosely assemble L-bracket for the end straps to the carriage bolt/plate assembled in **STEP 8**. Use washer and 5/16-18 nylon lock nut using 1/2" socket. The face of the L-bracket that is perpendicular to the mounting channel may face front or rear of the van depending on the shelf size and configuration.



- STEP 20.** Install the end strap to the L-bracket using 1/4-20 x 3/4" bolt, washer, and nylon lock nut using 7/16" wrench and socket. Position the strap such that it is inline with the end panel. Align the end strap to one of the holes on the end panel and secure it using 1/4-20 x 3/4" bolt, washer, and nylon lock nut. Make sure all components are aligned and tighten.

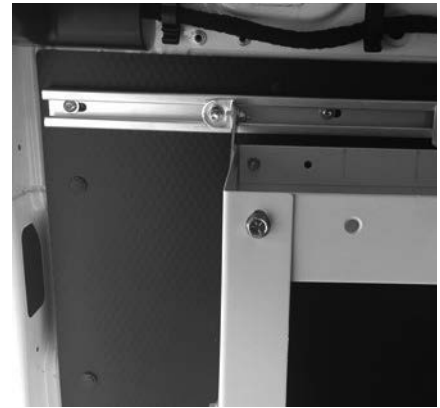

- STEP 21.** Make sure all shelves are aligned and make sure all bolts and nuts are properly torqued to spec. use 76 in-lbs for 1/4-20 hardware and 13 ft-lbs for 5/16-18 hardware.

## WARNING

This product is only intended and safe for use in storing and transporting small tools, equipment and other similar materials. These instructions are to be followed using the parts and fasteners supplied for proper installation. Any modifications or improper installation of this product will create a hazardous condition that could result in death, serious personal injury and/or property damage.

All floor mounting bolts near the fuel tank area should be installed from the underside of the vehicle, to guard against the fuel tank being punctured in the event of a collision. This would mean not using Blind Fasteners in this area. Holes in this area should be 5/16". Ensure ample space in roof ribs and sidewall ribs for mounting screws so as not to puncture exterior roof or wall. Do not install this product where it could interfere with deployment of air bags. Failure to comply could result in death or serious body injury.

## - NOTICE -

Any modification or unintended use of this product shall immediately void all manufacturers warranties. Manufacturer disclaims all liability for injuries to persons or property resulting from any modification to, or unintended use of this product.

## WERNER CO. LIMITED LIFETIME WARRANTY FOR WEATHER GUARD® PRODUCTS

### WEATHER GUARD® Products — Limited Lifetime Warranty (Purchased on or after 1/1/2009)

WERNER CO. (the "Manufacturer") warrants to the original purchaser only that WEATHER GUARD® Truck and Van Products (the "WEATHER GUARD® Product") will be free from defects in material and workmanship from the date of purchase and continuing for the expected lifetime of the WEATHER GUARD® Product. A copy of the original sales receipt must be supplied to the Manufacturer at the time a warranty claim is made. This warranty terminates if the original purchaser transfers the WEATHER GUARD® Product to any other person.

#### What is Covered

All WEATHER GUARD® Products identified above that are purchased on or after January 1, 2009.

#### What We Will Do to Correct Problems

Subject to the limitations and exclusions described in this limited warranty, the Manufacturer will remedy defects in materials or workmanship by providing one of the following remedies at its option and without charge to the original purchaser for parts or labor: (a) repairing the defective portion of the WEATHER GUARD® Product or (b) replacing the entire WEATHER GUARD® Product. In addition, the manufacturer may elect at its option, not to repair or replace the WEATHER GUARD® Product, but rather issue to the original purchaser a refund equal to the purchase price paid for the WEATHER GUARD® Product or a credit to be used toward the purchase of new WEATHER GUARD® Product.

#### What is Not Covered

This limited warranty expressly excludes:

- Defects caused by normal wear and tear, cosmetic rust, scratches, accidents, unlawful vehicle operation, or modification to the product, or any types or repair of a WEATHER GUARD® Product other than those authorized or provided by the Manufacturer.
- Defects resulting from conditions beyond the Manufacturer's control including, but not limited to misuse, overloading, or failure to assemble, mount or use the WEATHER GUARD® Product in accordance with the Manufacturer's written instructions or guidelines included with the WEATHER GUARD® Product or made available to the original purchaser.
- Damage to the contents of the box or vehicle.
- TO THE EXTENT PERMITTED BY LAW, IN NO EVENT SHALL THE MANUFACTURER BE LIABLE FOR ANY INCIDENTAL, SPECIAL, INDIRECT, OR CONSEQUENTIAL DAMAGES, INCLUDING ANY ECONOMIC LOSS, WHETHER RESULTING FROM NON-PERFORMANCE, USE, MISUSE OR INABILITY TO USE THE WEATHER GUARD® PRODUCT OR THE MANUFACTURER'S NEGLIGENCE.

#### No Other Express Warranty Applies

This Limited Lifetime Warranty is the sole and exclusive warranty for WEATHER GUARD® Products. No employee, agent, dealer, or other person is authorized to alter this warranty or make any other warranty on behalf of WERNER CO.

#### Notification Procedures

If the WEATHER GUARD® Product does not conform with the terms of this limited warranty, the original owner must promptly notify the Manufacturer in writing upon discovery of the nonconformity. In order to receive the remedies under this limited warranty, the warranty claim must describe the nature of the nonconformity, and a copy of the original sales receipt, invoice, bill or other proof of purchase must accompany the claim. Repairs or modifications made to the WEATHER GUARD® Product by other than the Manufacturer or its authorized agent will nullify this limited warranty. Coverage under this limited warranty is conditioned at all times upon the owner's compliance with these required notification and repair procedures. Warranty claims must include reciprocal contact information and may be made via certified mail to:

#### WERNER CO.

ATTN: Weather Guard® Warranty Claims  
555 Pierce Road, STE 300, Itasca, IL 60143 USA

[weatherguard.com](http://weatherguard.com)

If you have any questions, please call toll free at 1-800-456-7865