

# ASSEMBLY AND INSTALLATION INSTRUCTIONS

## ITEMIZER® Aluminum Drawer Units

### Models 314 • 316 • 317 • 318 • 326 • 327 • 328

#### IMPORTANT BEFORE YOU BEGIN

Read these instructions and warnings completely before installation.

**Approximate Assembly and Installation Time:**  
48 min. per unit (0.8 hrs.)  
Depending on Van equipment installation experience.

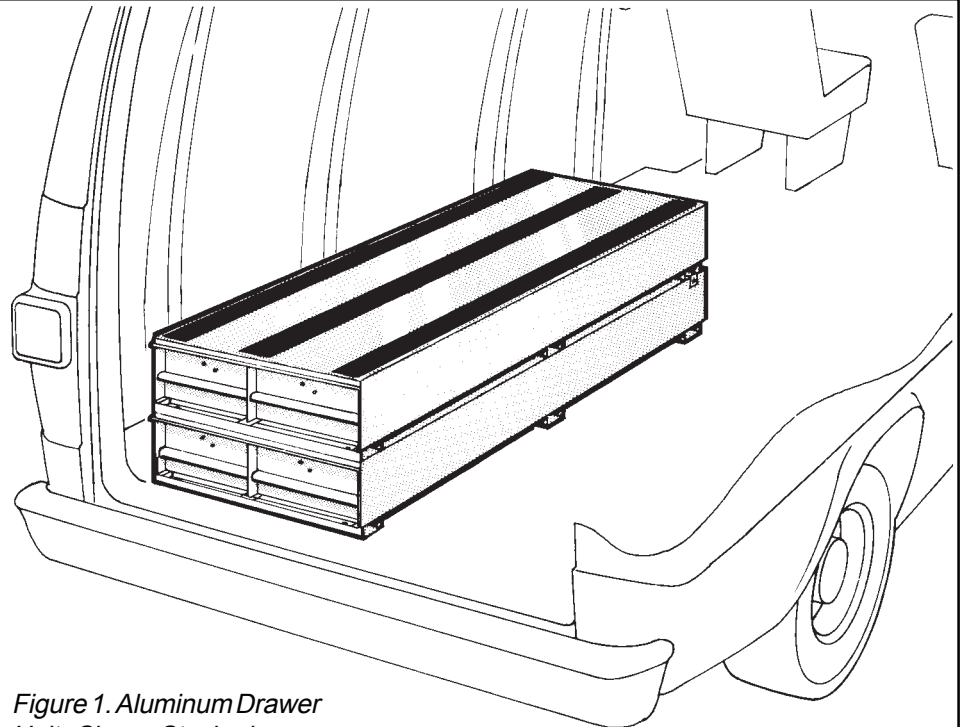

Figure 1. Aluminum Drawer Units Shown Stacked

#### BOLT KIT

Bolt Kit #32-0314 is provided with your Drawer Unit. Check this bolt kit to be sure the following parts are included:

Quan.	Description
6	1/4-20 x 3/4" Hex Hd. Bolt
4	1/4-20 Blind Fasteners
10	1/4" Flat Washers
6	1/4" Lock Washer, ext. tooth
1	1/4-20 x 2-1/4" Bolt, blk. ox.
1	Installation Tool
4	1/4-20 Nylon Lock Nuts

#### PARTS LIST

- 1- Drawer Unit
- 2- Mounting Brackets
- 6- Dividers (per drawer section)

#### TOOLS REQUIRED

- Drill with 5/16" & 13/32" drill bits
- 7/16" Open or Box End Wrench (2)
- 9/16" Open or Box End Wrench

## **⚠ DANGER**

**Danger of explosion. Do not use this product for storing or transporting flammables, explosives, hazardous materials, or hazardous waste, such as containers of gasoline, solvents, gun powder, dynamite, propane tanks, acetylene tanks and cutting torches. This product is only intended and safe for use in storing and transporting small tools, equipment and other similar materials. Any modifications made to, or unintended use of this product, could create a hazardous condition that can cause death, serious personal injury or property damage.**

#### ATTENTION: FOR ELECTRIC VEHICLES

Drilling into electrical wiring may damage vehicle systems and may cause bodily harm. This equipment should be installed by qualified personnel familiar with this type of vehicle and the hazards involved. To prevent damage to components underneath the floor, mainly the battery and high voltage system components, refer to your vehicle manufacturer's instructions or the manufacturer's website for more information. Before drilling for blind fasteners, check to make sure you won't be damaging wiring, gas lines, brake lines or other critical vehicle systems.



Figure 2. Front Mounting

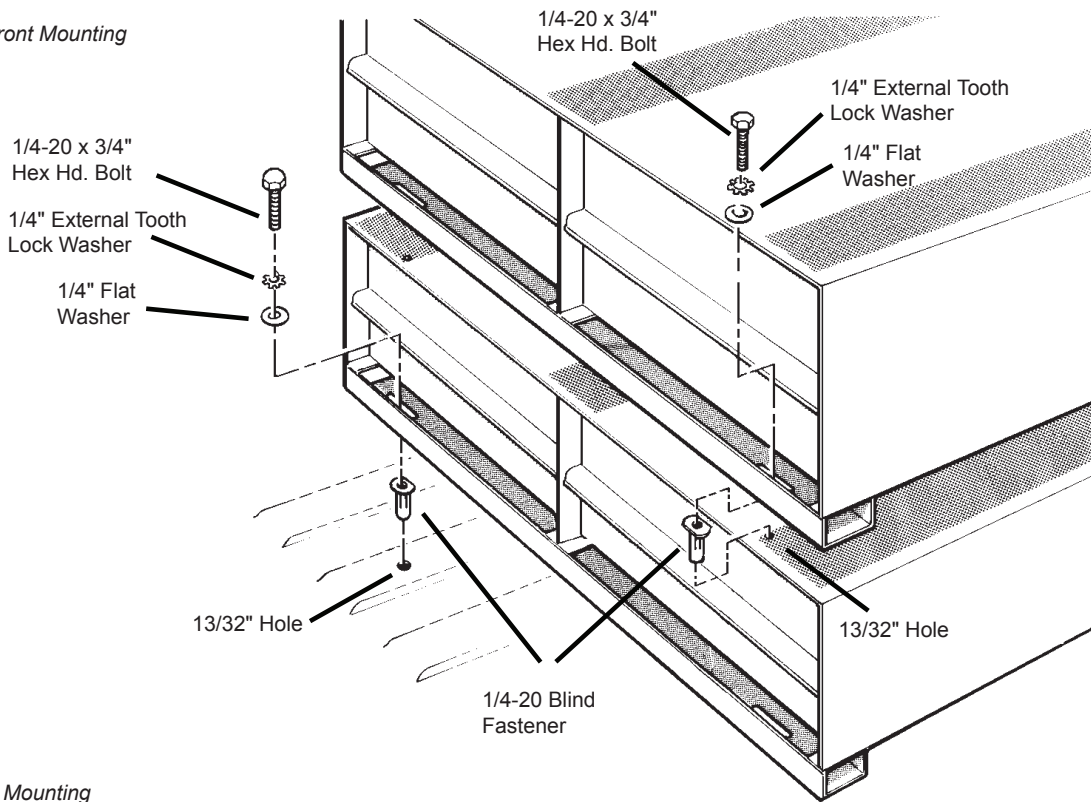
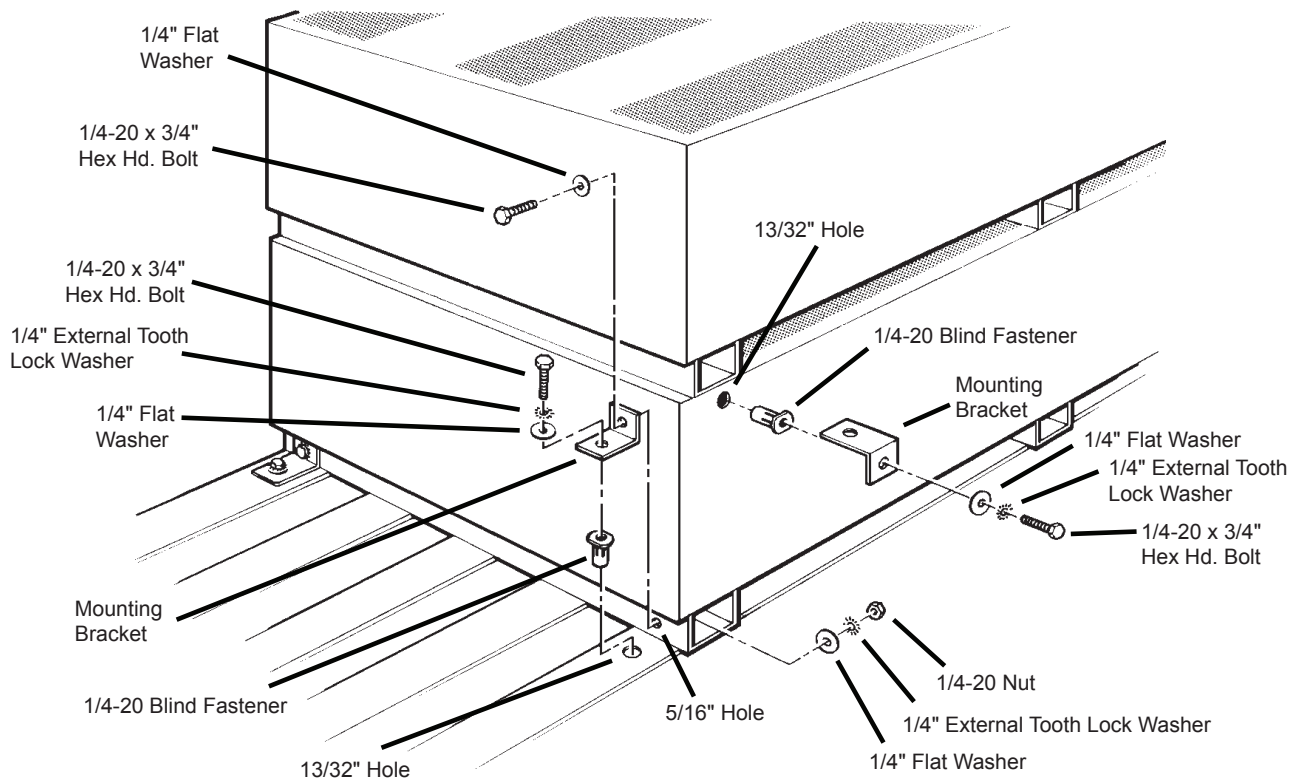

Figure 3. Rear Mounting



## INSTALLATION INSTRUCTIONS

1. Position the lower Drawer Unit in the vehicle, making sure the obround holes in the front skids are on top of the floor ribs (as shown in Figure 2). Mark the floor through the obround holes.
2. Go to the rear of the drawer unit (see Figure 3) and place the Mounting Brackets, as shown, with the longest side against the top of the floor rib. Mark through both sets of holes to the floor and the rear skid.

## ⚠ CAUTION

To keep debris out of your eyes when checking the underside of the vehicle, or when drilling, always wear protective eyewear.

## ⚠ WARNING

Prior to drilling, so as not to cut or puncture fuel tanks, fuel lines, brake lines, electric wires, etc., check under vehicle for locations.

## ⚠ WARNING

All floor mounting bolts near the gas tank area should be installed from the underside of the vehicle, to guard against the gas tank being punctured in the event of a collision. This would mean not using Blind Fasteners in this area. Holes drilled in this area should be 5/16".

## INSTALLATION PROCEDURE USING BLIND FASTENERS

### ⚠ WARNING

Prior to drilling, so as not to cut or puncture fuel tanks, fuel lines, brake lines, electric wires, etc., check under vehicle for locations.

**NOTE** - Be careful when drilling, or installing Blind Fastener, to ensure that there is enough clearance behind the surface so as not to damage the outer skin of the vehicle, roof members or vehicle components.

Place a drop of oil on the black oxide bolt before assembling as shown on right. Place the Blind Fastener in the hole and use a 1/2" or 7/16" wrench to tighten black hex bolt until the Blind Fastener is fully seated. When setting black hex bolt, it will start out hard. As the Blind Fastener "bulbs" out it will get easier, until it bottoms out or sets. Make sure the Blind Fastener and Installation Tool do not turn during installation.

3. Remove the drawer unit, drill the marked locations floor ribs for installation of four Blind Fasteners. Follow Blind Fasteners installation instructions listed below.
4. Drill the marked locations in the rear skid. Install the Mounting Bracket to the rear skid.
5. Replace the drawer unit into the vehicle and fasten.

## STACKING INSTRUCTIONS

6. Place the upper Drawer Unit on top of the previously installed lower unit. Align with the front of the lower unit (see Figure 2). Mark through the front skid obround holes to the lower unit.
7. Move the rear of the unit (see Figure 3) and place the long end of the Mounting Bracket into the open end of the rear skid. With the short end facing down, mark through the hole to the side of the lower unit.
8. Remove the upper drawer unit and drill the rear holes in the side of the lower unit. Drill the front skid holes and install Blind Fasteners.
9. Replace the upper unit and fasten.

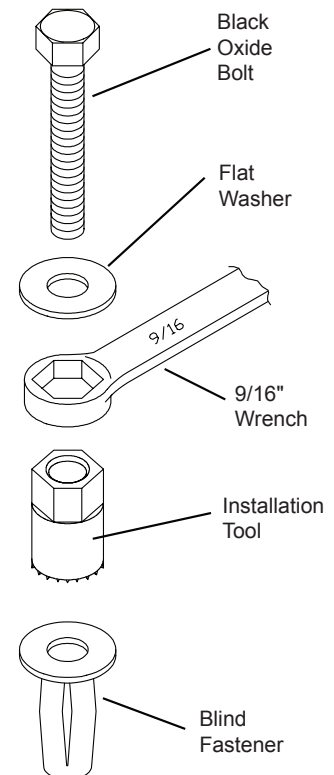

## -NOTICE-

Any modification or unintended use of this product shall immediately void all manufacturers warranties. Manufacturer disclaims all liability for injuries to persons or property resulting from any modification to, or unintended use of this product.

# WERNER CO. LIMITED LIFETIME WARRANTY FOR WEATHER GUARD® PRODUCTS

## WEATHER GUARD® Products — Limited Lifetime Warranty (Purchased on or after 1/1/2009)

WERNER CO. (the "Manufacturer") warrants to the original purchaser only that WEATHER GUARD® Truck and Van Products (the "WEATHER GUARD® Product") will be free from defects in material and workmanship from the date of purchase and continuing for the expected lifetime of the WEATHER GUARD® Product. A copy of the original sales receipt must be supplied to the Manufacturer at the time a warranty claim is made. This warranty terminates if the original purchaser transfers the WEATHER GUARD® Product to any other person.

### What is Covered

All WEATHER GUARD® Products identified above that are purchased on or after January 1, 2009.

### What We Will Do To Correct Problems

Subject to the limitations and exclusions described in this limited warranty, the Manufacturer will remedy defects in materials or workmanship by providing one of the following remedies at its option and without charge to the original purchaser for parts or labor: (a) repairing the defective portion of the WEATHER GUARD® Product or (b) replacing the entire WEATHER GUARD® Product. In addition, the Manufacturer may elect at its option, not to repair or replace the WEATHER GUARD® Product, but rather issue to the original purchaser a refund equal to the purchase price paid for the WEATHER GUARD® Product or a credit to be used toward the purchase of a new WEATHER GUARD® Product.

### What is Not Covered

This limited warranty expressly excludes:

- Defects caused by normal wear and tear, cosmetic rust, scratches, accidents, unlawful vehicle operation, or modification to the product, or any types or repair of a WEATHER GUARD® Product other than those authorized or provided by the Manufacturer.
- Defects resulting from conditions beyond the Manufacturer's control including, but not limited to misuse, overloading, or failure to assemble, mount or use the WEATHER GUARD® Product in accordance with the Manufacturer's written instructions or guidelines included with the WEATHER GUARD® Product or made available to the original purchaser.
- Damage to the contents of the box or vehicle.
- TO THE EXTENT PERMITTED BY LAW, IN NO EVENT SHALL THE MANUFACTURER BE LIABLE FOR ANY INCIDENTAL, SPECIAL, INDIRECT, OR CONSEQUENTIAL DAMAGES, INCLUDING ANY ECONOMIC LOSS, WHETHER RESULTING FROM NONPERFORMANCE, USE, MISUSE OR INABILITY TO USE THE WEATHER GUARD® PRODUCT OR THE MANUFACTURER'S NEGLIGENCE.

### No Other Express Warranty Applies

This Limited Lifetime Warranty is the sole and exclusive warranty for WEATHER GUARD® Products. No employee, agent, dealer, or other person is authorized to alter this warranty or make any other warranty on behalf of WERNER CO.

### Notification Procedures

If the WEATHER GUARD® Product does not conform with the terms of this limited warranty, the original owner must promptly notify the Manufacturer in writing upon discovery of the nonconformity. In order to receive the remedies under this limited warranty, the warranty claim must describe the nature of the nonconformity, and a copy of the original sales receipt, invoice, bill or other proof of purchase must accompany the claim. Repairs or modifications made to the WEATHER GUARD® Product by other than the Manufacturer or its authorized agent will nullify this limited warranty. Coverage under this limited warranty is conditioned at all times upon the owner's compliance with these required notification and repair procedures. Warranty claims must include reciprocal contact information and may be made via certified mail to:

#### WERNER CO.

ATTN: Weather Guard® Warranty Claims  
555 Pierce Road, STE 300 • Itasca, IL 60143 USA

[weatherguard.com](http://weatherguard.com)

If you have any questions, please call toll free at 1-800-456-7865

