

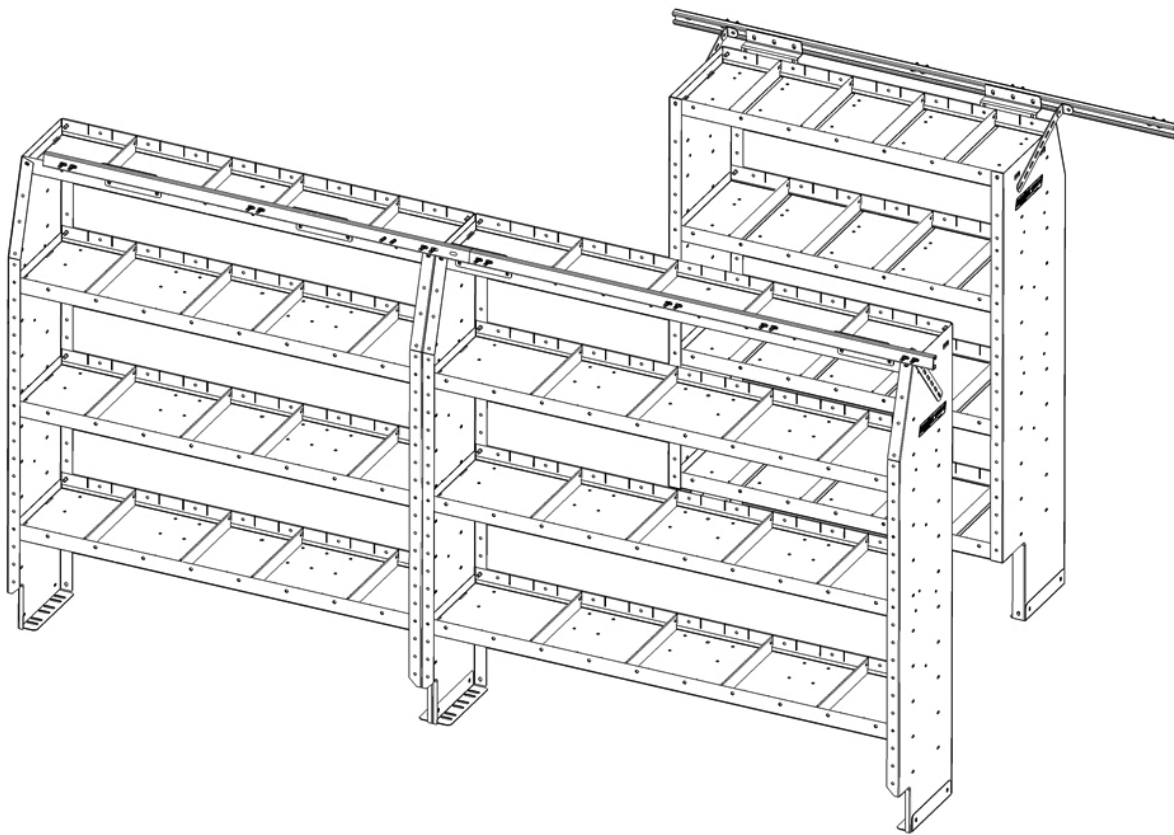

VAN STORAGE SOLUTIONS

**INSTALLATION INSTRUCTIONS for
MERCEDES SPRINTER
SHELVING MOUNTING KIT**



Weather Guard / WERNER CO.
420 E. Terra Cotta Ave.
Crystal Lake, IL 60014 USA

800-456-7865 (Toll Free)
800-334-2981 (Fax)

Weather Guard / WERNER CO.
9133 Leslie St. Unit 105
Richmond Hill, ON L4B4N1

888-562-2251 (Toll Free)
888-456-8460 (Fax)

ATTENTION: PLEASE READ AND UNDERSTAND ALL INSTRUCTIONS AND WARNINGS BEFORE ASSEMBLING, INSTALLING OR USING THIS PRODUCT.



PLAN YOUR VAN (TIPS FOR FASTER INSTALLATION)

FOR ELECTRIC VEHICLES – Drilling into electrical wiring may damage vehicle systems and may cause bodily harm. This equipment should be installed by qualified personnel familiar with this type of vehicle and the hazards involved. To prevent damage to components underneath the floor, mainly the battery and high voltage system components, refer to your vehicle manufacturer's instructions or the manufacturer's website for more information."

- Follow these instructions to install your WEATHER GUARD® van shelving inside a Mercedes Sprinter.
- Using these mounting brackets you will be able to install the van shelving using the obrounds in the van wall.
- Take into consideration any REDZONE end panel mounting accessories to be used and the desired location. The shelves can be easily adjusted.

HARDWARE KIT

Description	Quantity
Mounting Plate	20
5/16"-18 x 1-1/4 Button Head Bolt	25
1/4"-20 x 3/4" Bolt	16
5/16"-18 x 1" Carriage Bolt	20
1/4"-20 Nylon Lock Nut	16
5/16"-18 Nylon Lock Nut	20
1/4" Washer	16
Blind Fastener 5/16"-18	3
Blind Fastener Install Tool	1
5/16"-18 x 2-1/4" Bolt	1
5/16" Washer	45
Cap Rect. Red 3/4x1-5/8x1	4

TOOLS REQUIRED

3/16" Allen Wrench	Electric drill
7/16" Socket	Punch
7/16" Wrench	Hammer
1/2" Socket	1/4" drill bit
1/2" Wrench	3/8" drill bit
9/16" Wrench	1/2" drill bit
Level	Torque wrench
Marker	1" hole saw

CAUTION

Be safe—always wear protective eyewear to keep debris out of your eyes when installing WEATHER GUARD® van products.

PARTS LIST

975301-3-01 144" WB Sprinter

Description	Quantity
Shelf Bracket (common)	6
Liner Holder (common)	11
Plate (common)	11
Front Mounting Channel (common)	1
Rear Mounting Channel (63")	2

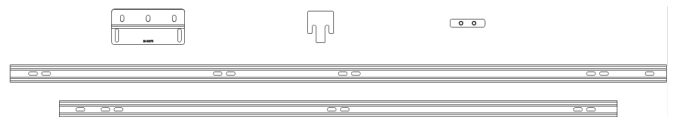

975302-3-01 170" WB Sprinter

Description	Quantity
Shelf Bracket (common)	8
Liner Holder (common)	11
Plate (common)	11
Front Mounting Channel (common)	1
Rear Mounting Channel (102.5")	2

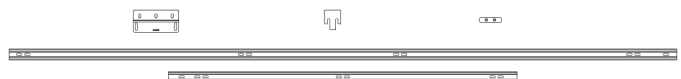

* Images not to scale.

MOUNTING KIT ASSEMBLY AND INSTALLATION INSTRUCTIONS

- The mounting channels will bolt to the van wall using a combination of plates and blind fasteners.
- Front mounting channel (driver side) is common across all wheelbase Sprinters.
- Rear mounting channels install in the same way, but have different lengths and plate locations.
- The Weather Guard Van Installation Kit is compatible with OEM interior trim kit.

STEP 1a. Liner Clip Removal

- If the van has wall liners, the black plastic pieces along the top of the wall (circled below) must first be removed before installing the channels. The front plastic piece on the driver side (marked with an "A" below) can likely be left in place.



STEP 1b. Low Roof Foam Block Removal

- If the van is a low roof model, the foam block at the front pillar (circled below) must first be removed.



MOUNTING KIT ASSEMBLY AND INSTALLATION INSTRUCTIONS

STEP 2. Install Blind Fasteners in the Van Wall

Middle Seam of Van

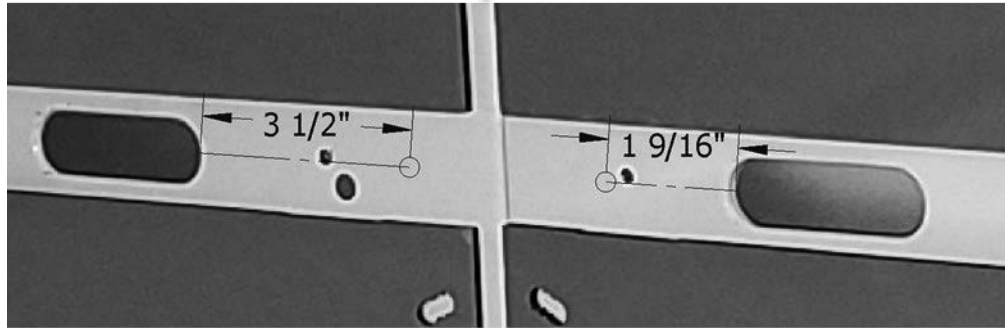

Driver Side (Front of Van is to the right)

Middle Seam of Van

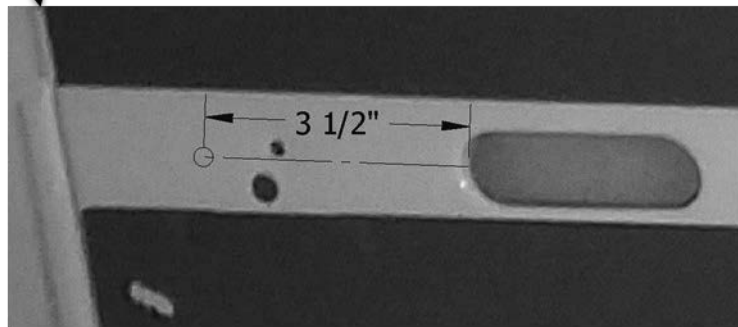

Passenger Side (Front of Van is to the left)

- Make a mark 3-1/2" in front of the van obround just behind the middle seam of the van on the driver side.
- Make a mark 1-9/16" behind the van obround just in front of the middle seam of the van on the driver side.
- Make a mark 3-1/2" in front of the front van obround on the passenger side of the van.
- Use a punch to indent the marked locations to drill out for blind fastener installation.
- Before drilling for blind fasteners, check to make sure you won't be damaging wiring, gas lines, or other critical vehicle systems.
- Too much pressure while drilling or setting the blind fasteners may cause dimples in the body panel around the install location.
- Use 1/4" drill bit to make pilot holes.
- Use 1/2" drill bit on pilot holes
- Install 5/16-18 blind fasteners using procedure shown on the next page.
- The individual slots marked below will be used for mounting to the blind fasteners in Step 4.



Front DS Channel

Rear Channel



MOUNTING KIT ASSEMBLY AND INSTALLATION INSTRUCTIONS

INSTALLATION PROCEDURE USING BLIND FASTENERS

Use 13mm socket (M8)
or 7/16" socket (1/4-20)

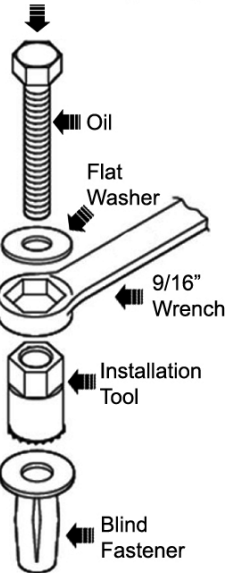

Place a drop of oil on the M8-1.25 x 55mm or 1/4-20 x bolt before assembling as shown on left.

Place the Blind Fastener in the hole and use a 13mm when installing M8 Blind Fastener or 7/16" socket when installing 1/4-20 Blind Fastener and driver to tighten the bolt until the Blind Fastener is fully seated.

When setting the bolt, it will start out tight. As the Blind Fastener "bulbs" out it will get easier, until it bottoms out of sets.

Make sure the Blind Fastener and the installation tool do not slip during the installation.

STEP 3. Assemble Plates to the Channels

- Attach the mounting plates to the channel by placing two 1-1/4" long 5/16-18 bolts with 5/16" washers through the slots in the channel and just barely threading the bolts into the nuts on the plate as shown.

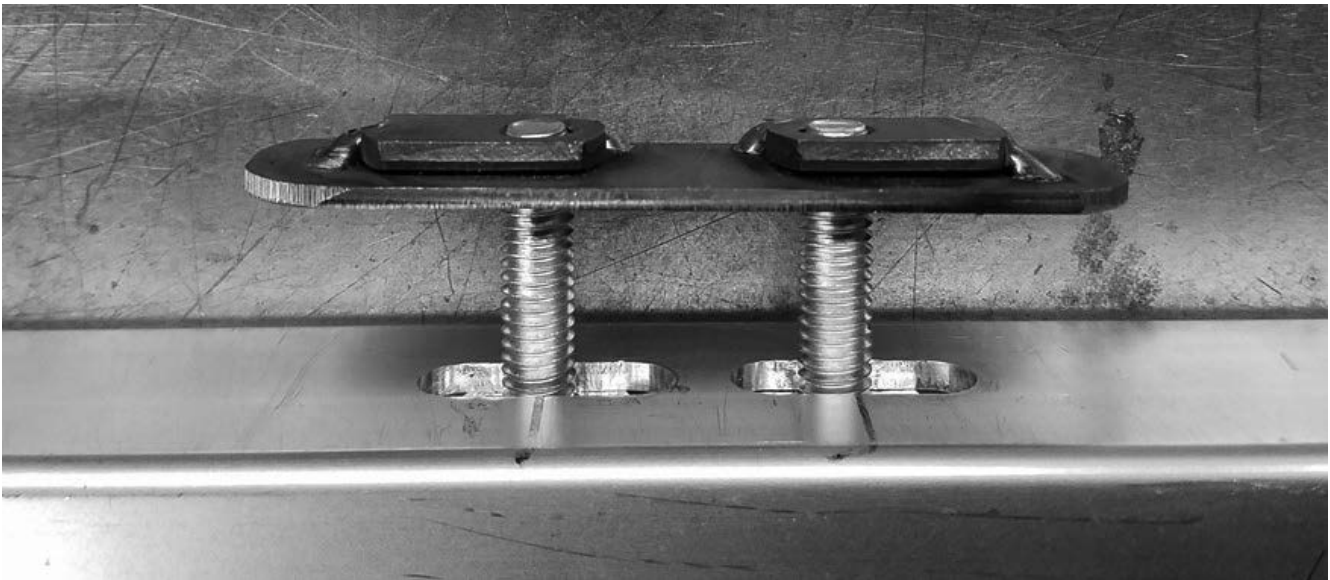

- The plates should be installed to the channels in each of the slot pairs marked below.

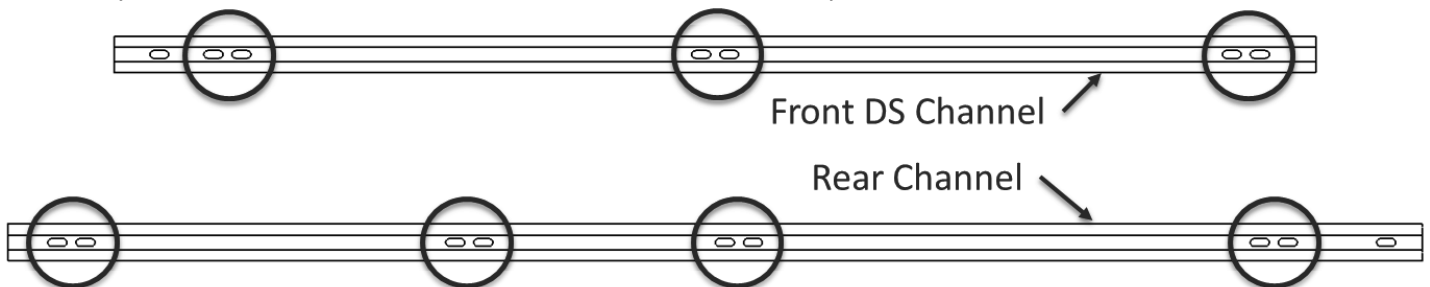

MOUNTING KIT ASSEMBLY AND INSTALLATION INSTRUCTIONS

STEP 4. Channel Placement

- Starting with the rear channel on the driver side, align the channel such that the plates line up with the obrounds in the van wall.



- Angle the front end of each plate into its respective obround and push them toward the front of the van until their back end can be pushed into the obround.



- Once all the plates are completely inside the obrounds, place a 5/16-18 bolt with a washer through the remaining channel slot and loosely thread it into the blind fastener.
- Repeat this process for the passenger side channel and the front driver side channel.



- If the van has wall liners, the provided liner holders must be installed between the channel and the liners at each plate location.
- Insert each liner holder from above. The long middle tongue will sit between the plate bolts and the holder will straddle the bolts.
- Ensure that all middle holder tongues are in front of, and overlapping, the lower liner.

MOUNTING KIT ASSEMBLY AND INSTALLATION INSTRUCTIONS

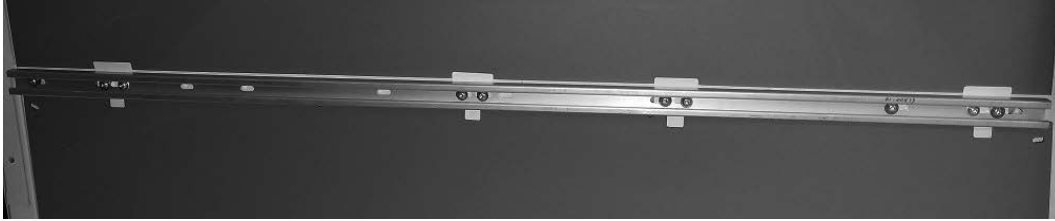
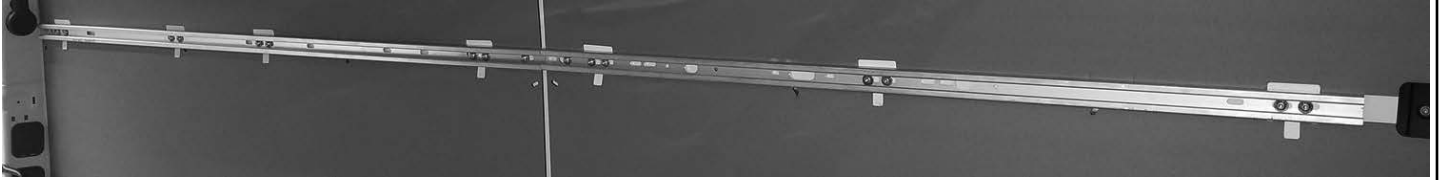

- Line up the edge of all three channels with the middle seam of the van.
- Tighten all the bolts using a 3/16" hex tool to 15 ft-lbs (in vans with wall liners, this may require a few passes as the liners and liner holders will compress as the bolts pull the channel tighter against the wall).

STEP 5. Position pre-assembled (minus mounting feet) shelving inside the van. Plan out positioning of the shelves and accessories relative to bulkhead and wheel well.



STEP 6. Two shelf units next to each other on driver side should be bolted together through the end panels using 1/4-20x3/4" bolts, washers, and nylon lock nuts.

STEP 7. Assemble two mounting brackets to the back of the top shelf lip on outer-most position shown below using two 1/4-20 x 3/4" bolts, washers, and nylon lock nuts. Do not torque them down at this point.

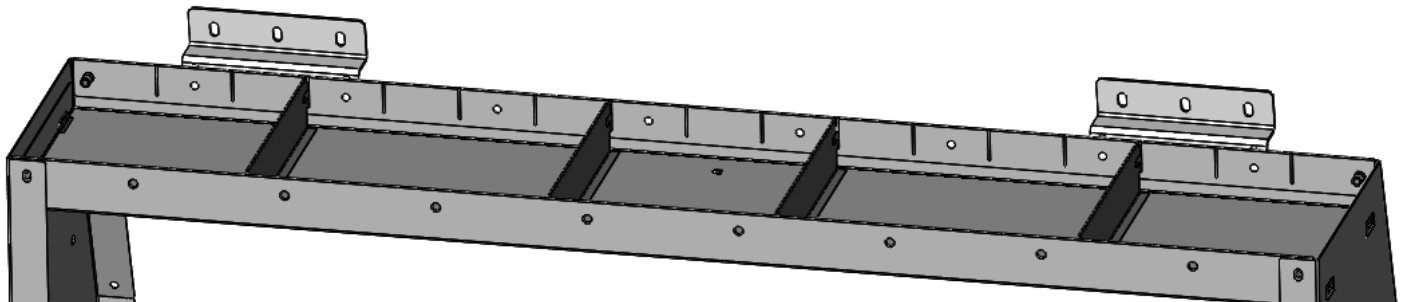

MOUNTING KIT ASSEMBLY AND INSTALLATION INSTRUCTIONS

- STEP 8.** Position the carriage bolt plate such that you can read the word "TOP" and insert 5/16-18 carriage bolt from the bottom of the plate. Note: using a piece of masking tape (or equivalent) on back of the plate to lightly hold the carriage bolt to the plate may allow easier installation. You will need four plates per shelving unit plus two for each side (driver/passenger) for the end straps.



- STEP 9.** Insert the carriage bolt/plate assemblies through the mounting channel and rotate 90 degrees clockwise. Ten will be used on driver side and six will be used on passenger side when installing standard configuration of two and one shelving for driver side and passenger side, respectively. Note: 170" wheelbase vans use three shelves on the driver side, thus, will require 14 carriage bolts/plates on driver side.

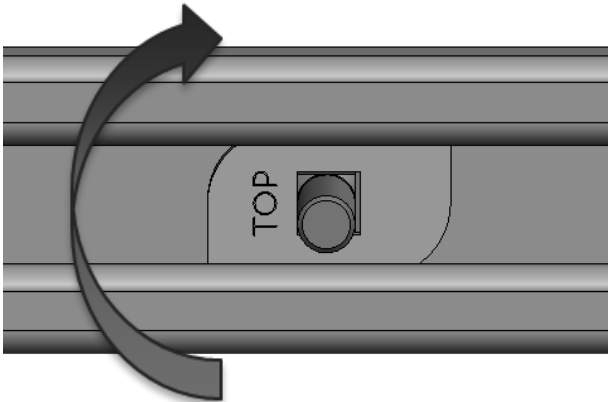

- STEP 10.** Position the shelves and carriage bolts/plates in desired location and fasten the shelves to the carriage bolt/plate using two 5/16-18 nylon lock nuts and washers using 1/2" socket. (Use outer two bracket slots if possible, but the middle bracket slot can be used if one of the outer slots causes interference) Fine tune the position and alignment of the shelves in desired location. Torque them down to 13 ft-lbs.



MOUNTING KIT ASSEMBLY AND INSTALLATION INSTRUCTIONS

STEP 11. Place the mounting foot to the inside of the end panel and mark drilling points. Use a spacer when mounting on uneven surface as shown below. Use a 1" hole saw if the van is equipped with floor mats. Use a 1/4" drill bit for pilot and 3/8" drill for 1/4-20 blind fasteners. Install 1/4-20 blind fasteners on the floor. Refer to blind fastener instruction on page 5. **Always be sure to make sure you won't be damaging wiring, gas lines, or other critical vehicle systems when drilling.**

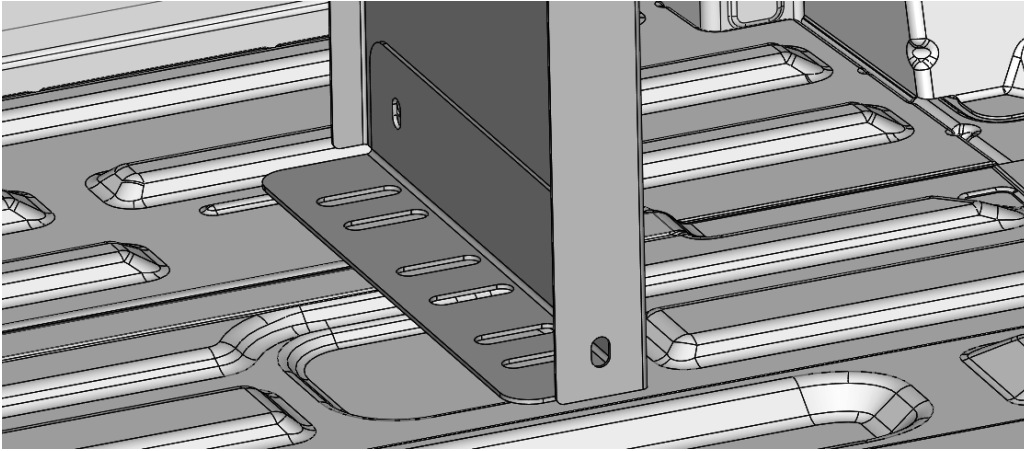

STEP 12. Slip the mounting foot from the other side of the end panel and install using 1/4-20 x 3/4" bolts, washers, and nylon lock nuts. Install to floor blind fasteners using 1/4-20 x 1-1/2" bolts. Repeat steps 11 and 12 until all mounting feet are installed. Note that you only need to use one mounting foot where the driver side shelves join.

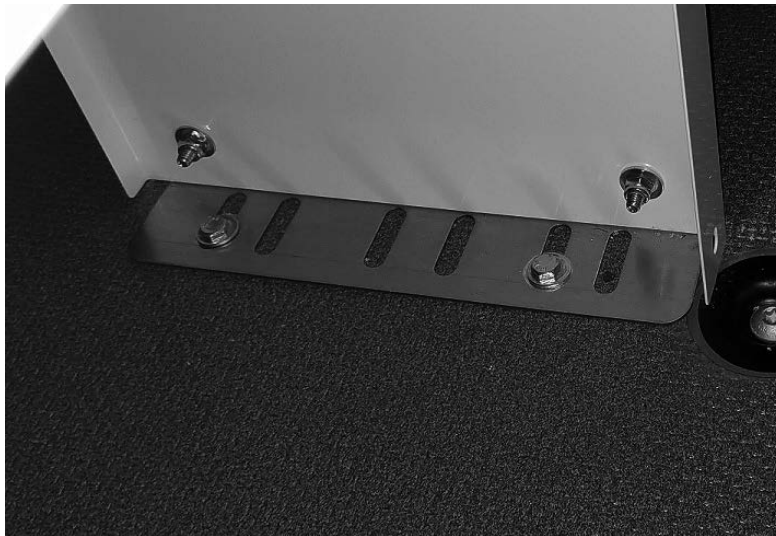

STEP 13. Torque down the 1/4-20 x 3/4" bolts, washers, and nylon lock nuts installed in **STEP 7** to 76 in-lbs.

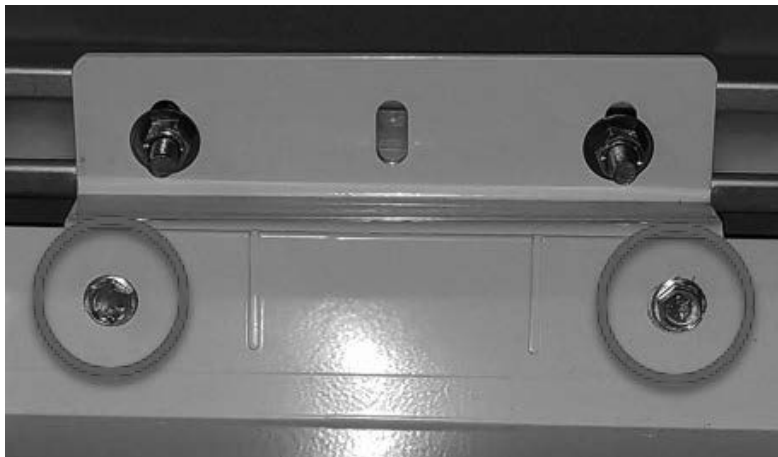

MOUNTING KIT ASSEMBLY AND INSTALLATION INSTRUCTIONS

- STEP 14.** Loosely assemble L-bracket for the end straps to the carriage bolt/plate assembled in **STEP 8**. Use washer and 5/16-18 nylon lock nut using 1/2" socket. The face of the L-bracket that is perpendicular to the mounting channel may face front or rear of the van depending on the shelf size and configuration.



- STEP 15.** Install the end strap to the L-bracket using 1/4-20 x 3/4" bolt, washer, and nylon lock nut using 7/16" wrench and socket. Position the strap such that it is inline with the end panel. Align the end strap to one of the holes on the end panel and secure it using 1/4-20 x 3/4" bolt, washer, and nylon lock nut. Make sure all components are aligned and tighten.

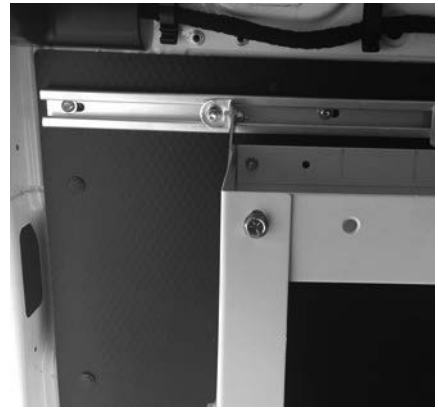

- STEP 16.** Make sure all shelves are aligned and make sure all bolts and nuts are properly torqued to spec. use 76 in-lbs for 1/4-20 hardware and 13 ft-lbs for 5/16-18 hardware.

WARNING

This product is only intended and safe for use in storing and transporting small tools, equipment and other similar materials. These instructions are to be followed using the parts and fasteners supplied for proper installation. Any modifications or improper installation of this product will create a hazardous condition that could result in death, serious personal injury and/or property damage.

All floor mounting bolts near the fuel tank area should be installed from the underside of the vehicle, to guard against the fuel tank being punctured in the event of a collision. This would mean not using Blind Fasteners in this area. Holes in this area should be 5/16". Ensure ample space in roof ribs and sidewall ribs for mounting screws so as not to puncture exterior roof or wall.

Do not install this product where it could interfere with deployment of air bags. Failure to comply could result in death or serious body injury.

- NOTICE -

Any modification or unintended use of this product shall immediately void all manufacturers warranties. Manufacturer disclaims all liability for injuries to persons or property resulting from any modification to, or unintended use of this product.

WERNER CO. LIMITED LIFETIME WARRANTY FOR WEATHER GUARD® PRODUCTS

WEATHER GUARD® Products — Limited Lifetime Warranty (Purchased on or after 1/1/2009)

WERNER CO. (the "Manufacturer") warrants to the original purchaser only that WEATHER GUARD® Truck and Van Products (the "WEATHER GUARD® Product") will be free from defects in material and workmanship from the date of purchase and continuing for the expected lifetime of the WEATHER GUARD® Product. A copy of the original sales receipt must be supplied to the Manufacturer at the time a warranty claim is made. This warranty terminates if the original purchaser transfers the WEATHER GUARD® Product to any other person.

What is Covered

All WEATHER GUARD® Products identified above that are purchased on or after January 1, 2009.

What We Will Do to Correct Problems

Subject to the limitations and exclusions described in this limited warranty, the Manufacturer will remedy defects in materials or workmanship by providing one of the following remedies at its option and without charge to the original purchaser for parts or labor: (a) repairing the defective portion of the WEATHER GUARD® Product or (b) replacing the entire WEATHER GUARD® Product. In addition, the manufacturer may elect at its option, not to repair or replace the WEATHER GUARD® Product, but rather issue to the original purchaser a refund equal to the purchase price paid for the WEATHER GUARD® Product or a credit to be used toward the purchase of new WEATHER GUARD® Product.

What is Not Covered

This limited warranty expressly excludes:

- Defects caused by normal wear and tear, cosmetic rust, scratches, accidents, unlawful vehicle operation, or modification to the product, or any types or repair of a WEATHER GUARD® Product other than those authorized or provided by the Manufacturer.
- Defects resulting from conditions beyond the Manufacturer's control including, but not limited to misuse, overloading, or failure to assemble, mount or use the WEATHER GUARD® Product in accordance with the Manufacturer's written instructions or guidelines included with the WEATHER GUARD® Product or made available to the original purchaser.
- Damage to the contents of the box or vehicle.
- TO THE EXTENT PERMITTED BY LAW, IN NO EVENT SHALL THE MANUFACTURER BE LIABLE FOR ANY INCIDENTAL, SPECIAL, INDIRECT, OR CONSEQUENTIAL DAMAGES, INCLUDING ANY ECONOMIC LOSS, WHETHER RESULTING FROM NON-PERFORMANCE, USE, MISUSE OR INABILITY TO USE THE WEATHER GUARD® PRODUCT OR THE MANUFACTURER'S NEGLIGENCE.

No Other Express Warranty Applies

This Limited Lifetime Warranty is the sole and exclusive warranty for WEATHER GUARD® Products. No employee, agent, dealer, or other person is authorized to alter this warranty or make any other warranty on behalf of WERNER CO.

Notification Procedures

If the WEATHER GUARD® Product does not conform with the terms of this limited warranty, the original owner must promptly notify the Manufacturer in writing upon discovery of the nonconformity. In order to receive the remedies under this limited warranty, the warranty claim must describe the nature of the nonconformity, and a copy of the original sales receipt, invoice, bill or other proof of purchase must accompany the claim. Repairs or modifications made to the WEATHER GUARD® Product by other than the Manufacturer or its authorized agent will nullify this limited warranty. Coverage under this limited warranty is conditioned at all times upon the owner's compliance with these required notification and repair procedures. Warranty claims must include reciprocal contact information and may be made via certified mail to:

WERNER CO.

ATTN: Weather Guard® Warranty Claims
555 Pierce Road, STE 300, Itasca, IL 60143 USA

weatherguard.com

If you have any questions, please call toll free at 1-800-456-7865