



**TRUCK STORAGE SOLUTIONS**  
**SECURING YOUR REPUTATION**

# INSTALLATION MANUAL

## FULL-SIZE TRUCK RACK

ATTENTION: PLEASE READ AND UNDERSTAND ALL INSTRUCTIONS AND WARNINGS BEFORE ASSEMBLING, INSTALLING OR USING THIS PRODUCT.

**MODEL** 1275-52-02 Full Size Steel Truck Rack (1,000 lb. Rating)

**Note:** X represents the color code for your model: 0 = Clear | 3 = White | 5 = Black | 52 = Matte Black



### ⚠ NOTICE

There may be left over components depending on up-fit. Any modification or unintended use of this product shall immediately void all manufacturer's warranties. Manufacturer disclaims all liability for injuries to persons or property resulting from any modification to, or unintended use of this product.

### ⚠ DANGER

Danger of explosion. Do not use this product for storing or transporting flammables, explosives, hazardous materials, or hazardous waste, such as containers of gasoline, solvents, gun powder, dynamite, propane tanks, acetylene tanks and cutting torches.

### ⚠ CAUTION

To keep debris out of your eyes when checking the underside of the vehicle, or when drilling, always wear protective eyewear. Never load your rack to exceed the safe rated capacity of your vehicle. Heavy loads carried high can dangerously alter the center of gravity.











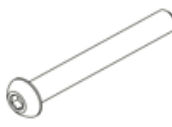

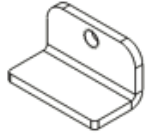

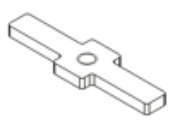

### ⚠ WARNING

Always place and tightly secure ladder on rack with a sufficient barrier (tape/padding) between the ladder and rack. Failure to properly secure the ladder on the rack while in transit could cause damage leading to structural collapse of the ladder and potential injury or death. This product is only intended for, and only safe for, transporting ladders, lumber, pipe and other similar materials. It is the responsibility of the user to secure these materials to the rack before transporting. Any modifications made to this product, or use of this product for any other purpose than its intended use, could create a hazardous condition that can cause serious personal injury or property damage. This product is only intended and safe for use in storing and transporting small tools, equipment and other similar materials. Any modifications made to, or unintended use of this product, could create a hazardous condition that can cause death, serious personal injury or property damage.

## TOOLS REQUIRED

- Rubber Hammer
- Utility Knife
- Allen Key (1/8", 7/32", 5/16")
- Open End Wrench (9/16", 3/4")

## PARTS LIST

<p><b>A</b></p>  <p>(8) 1/2-13 x 3" Bolt</p>	<p><b>B</b></p>  <p>(4) 1/2-13 x 4" Bolt</p>	<p><b>C</b></p>  <p>(12) 3/8-16 x 2-1/2" Bolt</p>	<p><b>D</b></p>  <p>(18) 3/8-16 x 1" Bolt</p>	<p><b>E</b></p>  <p>(8) No Drill Bracket</p>
<p><b>F</b></p>  <p>(26) 3/8-16 Nylock Nut</p>	<p><b>G</b></p>  <p>(4) 1/2-13 Nylock Nut</p>	<p><b>H</b></p>  <p>(4) 3/8" Locking Pin</p>	<p><b>I</b></p>  <p>(8) Plug</p>	<p><b>J</b></p>  <p>(4) Stake Pocket Bracket</p>
<p><b>K</b></p>  <p>(16) 1/2" Flat Washer</p>	<p><b>L</b></p>  <p>(26) 3/8" Flat Washer</p>	<p><b>M</b></p>  <p>(4) 3/8" Split Washer</p>	<p><b>N</b></p>  <p>Silicone</p>	<p><b>P</b></p>  <p>(4) 1/4-20 Set Screw</p>
<p><b>Q</b></p>  <p>(6) End Cap</p>	<p><b>R</b></p>  <p>(2) 1/2-13 x 1" Bolt</p>	<p><b>S</b></p>  <p>(10) 1/2" Split Washer</p>	<p><b>T</b></p>  <p>1/2" Fender Washer</p>	<p><b>U</b></p>  <p>(2) Stake Pocket Side Mount</p>

### Assembly Recommendation:

- 1) If user plans on carrying ladders, it is recommended to reverse the carriage bolts to have the bolt head on the inside of the rack.
- 2) Before applying protective strip, make sure cross members are clean and clear of any debris.

## RACK ASSEMBLY

### STEP 1 Silicone Application:

Apply a minimum of 2 beads of silicone (Part N) around all swages. If there is a hole, silicone should be applied on either side of the hole. Silicone should also be applied around the outer hole surfaces where the bolt and the washer touch the tube.

### STEP 2 Install End Caps (Part Q) onto both cross members and rear arms.



### STEP 3 Identify the driver side and passenger side front arms by locating the biased side joint plate. The driver side front arm joint plate will be biased to the left (driver side) with the weld also on the left side. Attach the driver side rear arm to the front arm using (3) Part D, (3) Part L, and (3) Part F.

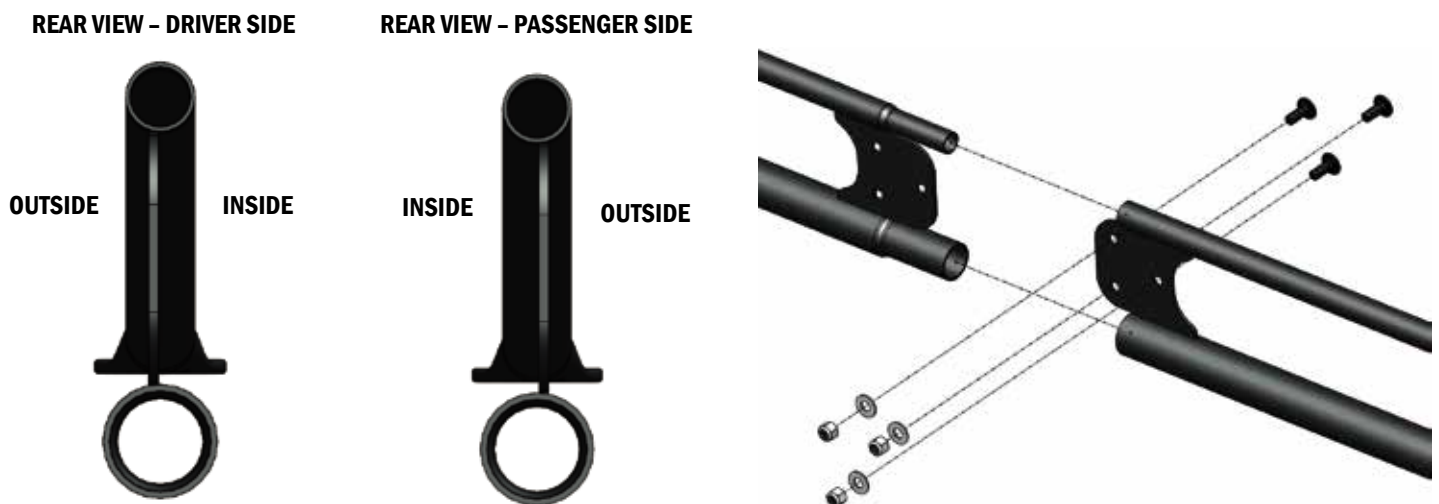

**STEP 4** Install the rear leg, with the tie down facing the outside using (1) Part C, (1) Part L, and (1) Part F. The outside plate will have the Weather Guard® logo.



**STEP 5** Install the front leg to the driver side arm assembly by sliding the leg guide tube over the lower tube while making sure the plate is on the outside of the assembly and the c-channel and gusset are on the inside of the assembly. Loosely secure the front leg using the leg clamp bracket with (2) Part D, (2) Part L, and (2) Part F. Loosely install set screws (Part P).

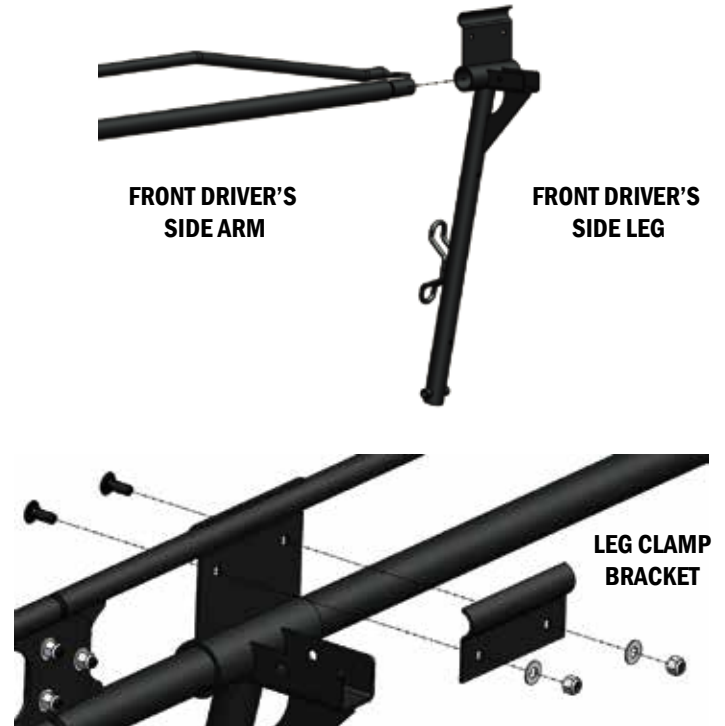

**INSTALLATION TIP:**

Loosely install legs to the plates that attach to the front and rear side members to make installation of the Cross Member easier.

**STEP 6** Repeat steps 3 - 5 for the passenger side.

**STEP 7** Install center cross member, the cross member without the Weather Guard® logo, to one of the front legs using (2) Part C, (2) Part L, and (2) Part F.

Tilt the assembly up and balance the assembly on the legs while installing to the opposite front leg using (2) Part C, (2) Part L, and (2) Part F.

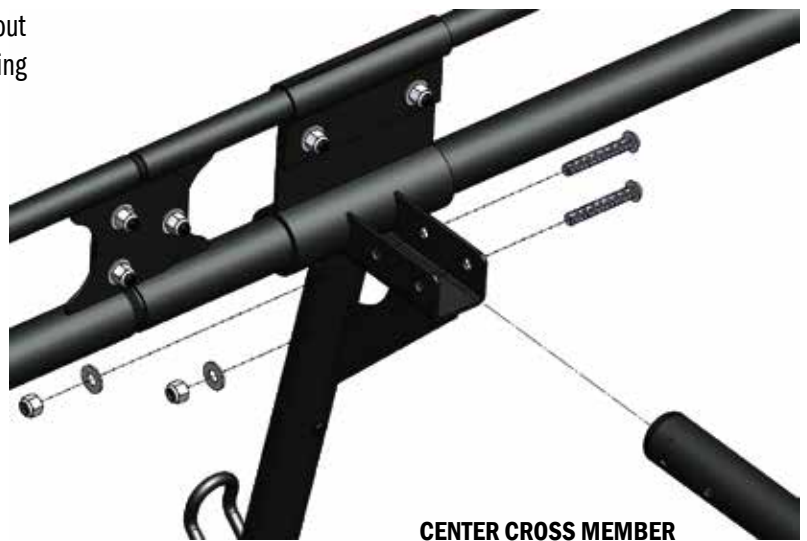

**STEP 8** Repeat step 6 with the rear cross member, making sure the Weather Guard® logo faces upright and towards the tailgate. Use locking pins (Part H) instead of nuts and bolts.



**STEP 9** Install front hoop, making sure the air foil is pointing downward. On each side, use (1) Part C, (1) Part L, (1) Part F to install the hoop to the front assemblies.

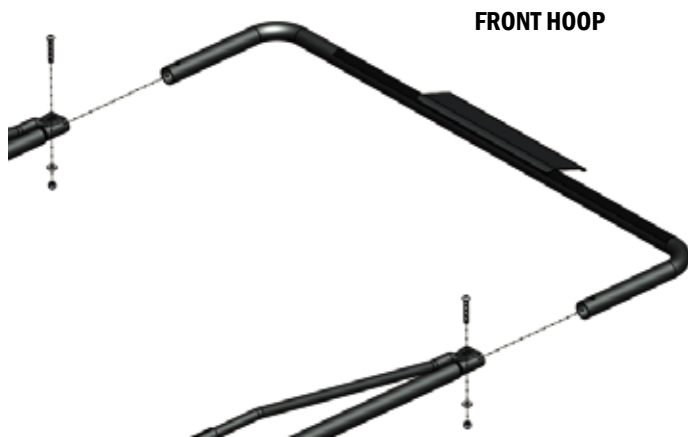

**STEP 10** Install support brackets if the truck is less than 8' using (4) Part D, (4) Part L, and (4) Part F on each side. This will be installed within 1 inch of the bend on the driver side and passenger side front arms.

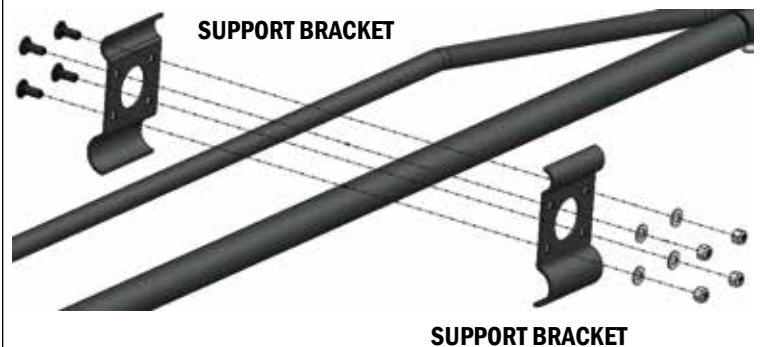

# RACK INSTALLATION

**STEP 11** Install the front (cab side) mounting feet to the truck bed. Place the mounting foot onto the truck bed placing the foot as far forward as possible. Find the most appropriate hole that aligns with the center of the stake pocket. Insert the hardware, using (1) Part J, (1) Part C, and (1) Part M, into the stake pocket and thread the stake pocket bracket (Part J) to the end of the bolt. Insert the stake pocket bracket into the stake pocket by tilting the foot assembly and inserting the bracket diagonally into the stake pocket. Loosely tighten the stake pocket bracket then install the no drill mount bracket (Part E) to the rear most mounting foot clamp insert hole using (1) Part A, (1) Part K, and (1) Part E. Tighten hardware, making sure mounting foot is secured to the bed rail.

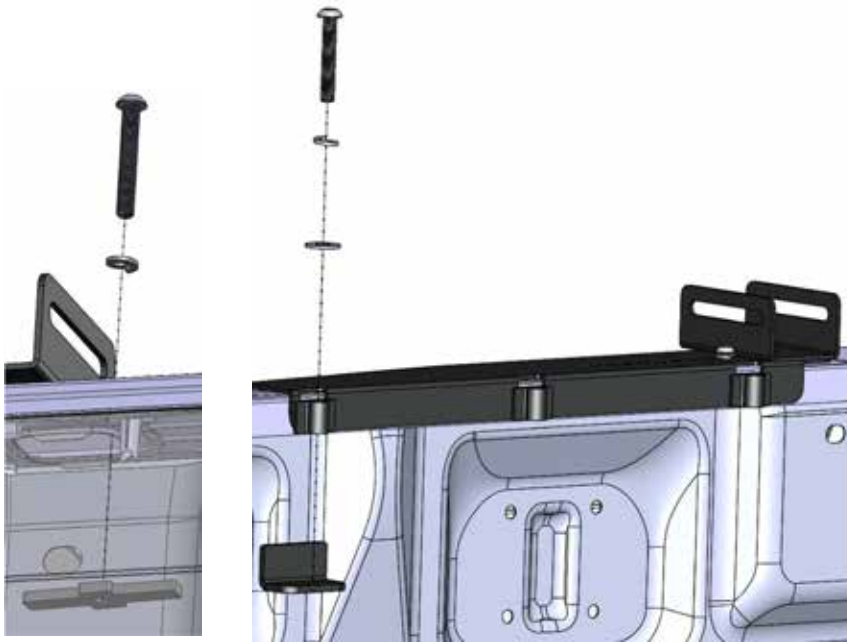

## PRO TIP:

1. When installing the mounting feet and utilizing the stake pocket bracket, always use the furthest no drill mounting location from the stake pocket when possible. If your bed has structure in the way of installing the no drill bracket in the furthest mount from the stake pocket, use the center mounting location.
2. If your truck does not have stake pockets, use 2 no drill brackets. Always use the closest mounting location to the leg, as well as one of the other 2 locations. When possible mount using the outer most mounting locations.

**NOTE:** The front driver side foot is the same as the rear passenger side foot. The front passenger side foot is the same as the rear driver side foot.

**STEP 12** Install rear (tailgate side) mounting feet to the truck bed. It is recommended to use the single center hole in the mounting pad for securing the rear feet when possible. (If the vehicle is a 2016 or newer Chevrolet/GMC truck refer to Step 13). Insert the hardware, using (1) Part J, (1) Part C, and (1) Part M, into the stake pocket and thread the stake pocket bracket (Part J) to the end of the bolt. Insert the stake pocket bracket into the stake pocket by tilting the foot assembly and inserting the bracket diagonally into the stake pocket. Loosely tighten the stake pocket bracket then install the no drill mount bracket (Part E) to the front most mounting foot clamp insert hole using (1) Part A, (1) Part K, and (1) Part E. Tighten hardware, making sure mounting foot is secured to the bed rail.



**STEP 13 2016 or Newer Chevrolet/GMC Trucks Only**

Use the stake pocket side mount in the rear stake pockets only. This will mount in the stake pocket via the side hole. This will also replace the stake pocket bracket for the rear. Install the no-drill mounting bracket (Part U) to the rear most mounting hole using (1) Part R, (1) Part S, and (1) Part T. Tighten hardware, making sure mounting foot is secured to the bed rail. Repeat on opposite rear stake pocket.

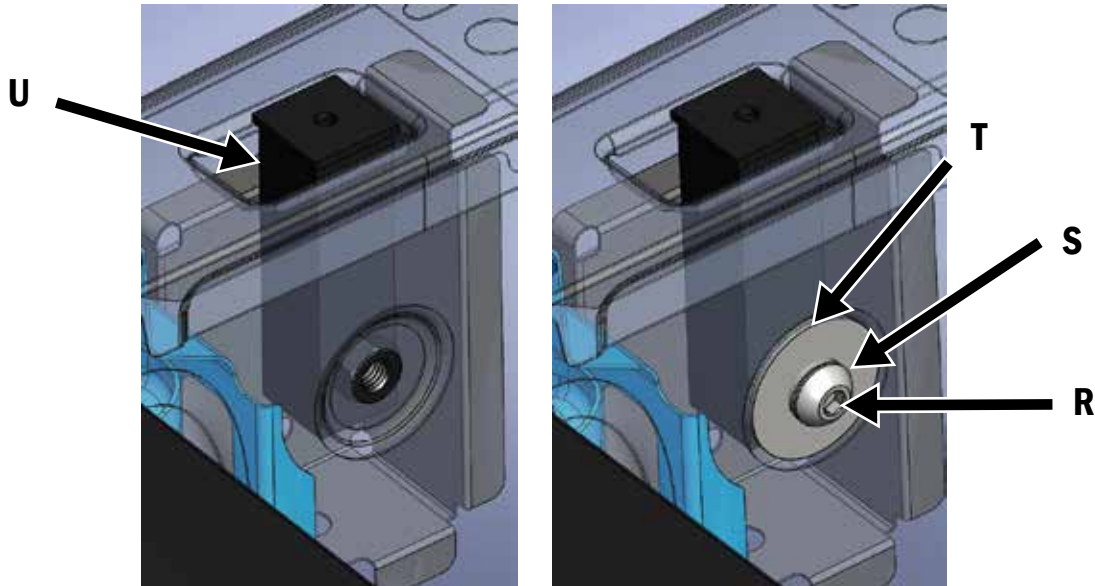

**STEP 14** Apply the rubber protective strip to the top of each of the cross members.

**STEP 15** Insert all 8 plastic plugs (Part I) into the holes of the front legs.



**STEP 16** Measure the distance from center to center of mounting foot bed and set the rack assembly accordingly. Tighten all hardware with a 3/8"-16 button head to a 15 ft-lb torque and tighten all other hardware to a 25 ft-lb torque except the front legs hardware. (DO NOT TIGHTEN THE SET SCREWS ON THE FRONT LEGS).



**STEP 17** Install rack onto truck using (1) Part B, (2) Part K, and (1) Part G for each leg. Mounting hardware is to be torqued to 25 ft-lb torque. Prior to tightening rear make sure pins on rear cross member can be removed.

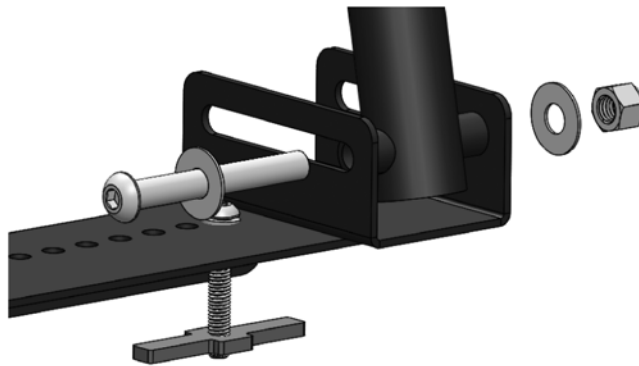

## SAFETY

1. Evenly distribute load over width and length of rack.
2. Material must be contained within the side rails of rack.
3. Do not use upper rail as a tie down point.
4. If material being secured does not sit higher than the upper rail, the tie down strap must pass under the upper rail.
5. Material should be secured using the available tie down points for the rear and center cross members, as well as the front cross member when applicable.
6. Do not load material on side rails.
7. When loading or storing a ladder, the protective strip supplied must be used.
8. Never overload the rack with material greater than the racks rating (1,000 lbs).
9. Adhere to DOT and state requirements when transporting material on rack.
10. Properly rated straps must be used when securing material to rack.
11. Vehicle stability could be greatly reduced in the event that too much weight is placed on rack and vehicle. The rating of the rack may be greater than the vehicle's load ratings. Weather Guard recommends consulting the vehicle manufacturer before loading material for assistance.
12. Do not use rack with Rear Cross-Member removed.
13. Replace any rack members or rack itself if damaged.
14. Remove rack if vehicle bed rails or truck bed are damaged.
15. Do not use a forklift to load material.



# WERNER CO. LIMITED LIFETIME WARRANTY FOR WEATHER GUARD® PRODUCTS

## WEATHER GUARD® Products – Limited Lifetime Warranty (Purchased on or after 1/1/2009)

WERNER CO. (the “Manufacturer”) warrants to the original purchaser only that WEATHER GUARD® Truck and Van Products (the “WEATHER GUARD® Product”) will be free from defects in material and workmanship from the date of purchase and continuing for the expected lifetime of the WEATHER GUARD® Product. A copy of the original sales receipt must be supplied to the Manufacturer at the time a warranty claim is made. This warranty terminates if the original purchaser transfers the WEATHER GUARD® Product to any other person.

### What is Covered

All WEATHER GUARD® Products identified above that are purchased on or after January 1, 2009.

### What We Will Do To Correct Problems

Subject to the limitations and exclusions described in this limited warranty, the Manufacturer will remedy defects in materials or workmanship by providing one of the following remedies at its option and without charge to the original purchaser for parts or labor: (a) repairing the defective portion of the WEATHER GUARD® Product or (b) replacing the entire WEATHER GUARD® Product. In addition, the Manufacturer may elect at its option, not to repair or replace the WEATHER GUARD® Product, but rather issue to the original purchaser a refund equal to the purchase price paid for the WEATHER GUARD® Product or a credit to be used toward the purchase of a new WEATHER GUARD® Product.

### What is Not Covered

This limited warranty expressly excludes:

- Defects caused by normal wear and tear, cosmetic rust, scratches, accidents, unlawful vehicle operation, or modification to the product, or any types or repair of a WEATHER GUARD® Product other than those authorized or provided by the Manufacturer.
- Defects resulting from conditions beyond the Manufacturer’s control including, but not limited to misuse, overloading, or failure to assemble, mount or use the WEATHER GUARD® Product in accordance with the Manufacturer’s written instructions or guidelines included with the WEATHER GUARD® Product or made available to the original purchaser.
- Damage to the contents of the box or vehicle.
- TO THE EXTENT PERMITTED BY LAW, IN NO EVENT SHALL THE MANUFACTURER BE LIABLE FOR ANY INCIDENTAL, SPECIAL, INDIRECT, OR CONSEQUENTIAL DAMAGES, INCLUDING ANY ECONOMIC LOSS, WHETHER RESULTING FROM NONPERFORMANCE, USE, MISUSE OR INABILITY TO USE THE WEATHER GUARD® PRODUCT OR THE MANUFACTURER’S NEGLIGENCE.

### No Other Express Warranty Applies

This Limited Lifetime Warranty is the sole and exclusive warranty for WEATHER GUARD® Products. No employee, agent, dealer, or other person is authorized to alter this warranty or make any other warranty on behalf of WERNER CO.

### Notification Procedures

If the WEATHER GUARD® Product does not conform with the terms of this limited warranty, the original owner must promptly notify the Manufacturer in writing upon discovery of the nonconformity. In order to receive the remedies under this limited warranty, the warranty claim must describe the nature of the nonconformity, and a copy of the original sales receipt, invoice, bill or other proof of purchase must accompany the claim. Repairs or modifications made to the WEATHER GUARD® Product by other than the Manufacturer or its authorized agent will nullify this limited warranty. Coverage under this limited warranty is conditioned at all times upon the owner’s compliance with these required notification and repair procedures. Warranty claims must include reciprocal contact information and may be made via certified mail to:

WERNER CO.  
ATTN: Warranty Claims  
420 E. Terra Cotta Avenue  
Crystal Lake, IL 60014



If you have any questions,  
please call toll free at 1-800-456-7865

WEATHER GUARD® Products are protected by one or more of the following trademarks:  
U.S. - 842268, 1661625, 1663369, 1750034, 2228051, 2291111, 2362167; Canada - 282725; U.K. - 1400720; N.Z. - 296049; AUS - 761964. Other trademarks pending.

**WERNERCO™**