

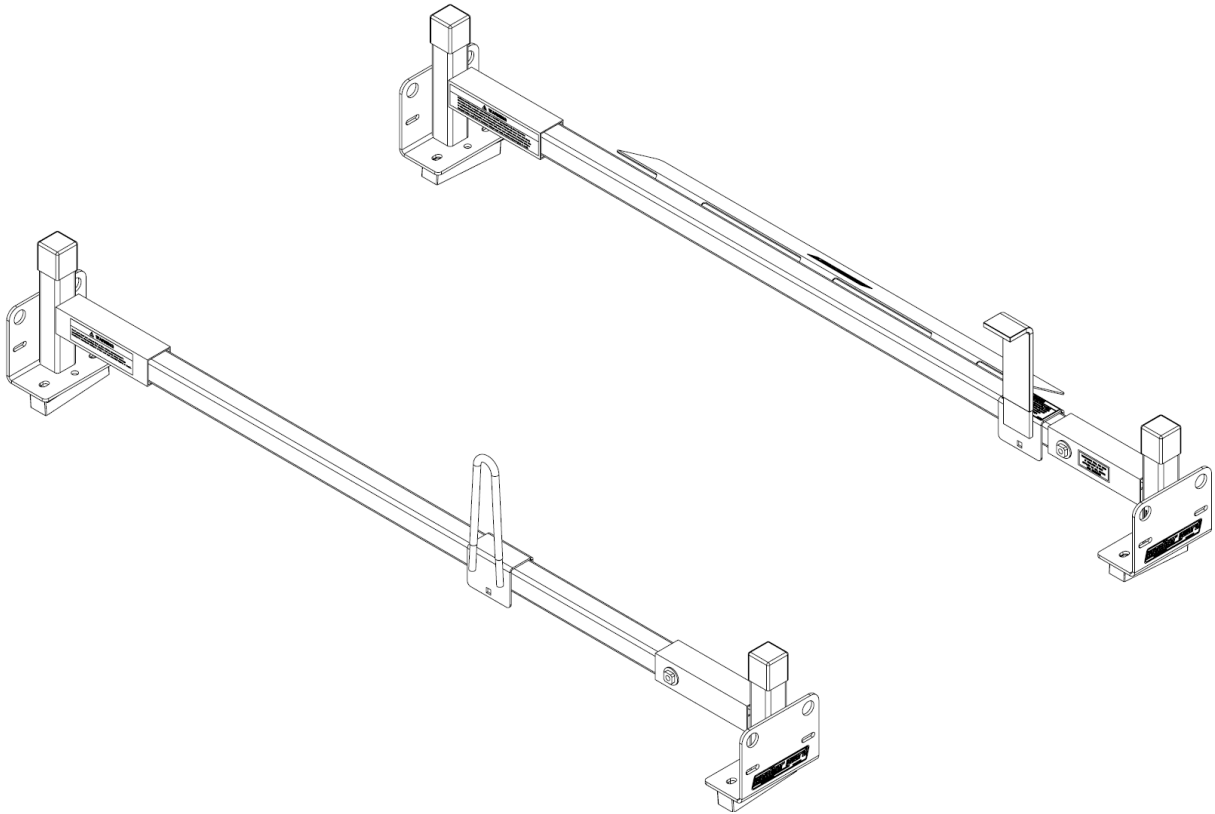

**VAN STORAGE SOLUTIONS**  
FOR THE WAY YOU WORK™

# INSTALLATION INSTRUCTIONS for METRIS STEEL VAN RACK & ACCESSORY CROSS MEMBER



## MODELS 22002 AND 22102

Weather Guard / KNAACK  
420 E. Terra Cotta Ave.  
Crystal Lake, IL 60014 USA

800-456-7865 (Toll Free)  
800-334-2981 (Fax)  
Knaack.OrderEntry@wernerco.com

Weather Guard / KNAACK  
9133 Leslie St. Unit 105  
Richmond Hill, ON L4B4N1

888-562-2251 (Toll Free)  
888-456-8460 (Fax)  
Knaack.OrderEntry.Canada@wernerco.com

ATTENTION: PLEASE READ AND UNDERSTAND ALL INSTRUCTIONS AND WARNINGS  
BEFORE ASSEMBLING, INSTALLING OR USING THIS PRODUCT.

## INSTALLATION GUIDELINES

- WEATHER GUARD® ladder racks are designed to work with OEM mounting points or with WEATHER GUARD® Mounting Channel kits to provide the best support for your ladders and to take advantage of OEM provided roof mounting points. If you intend to, but have not already installed the mounting channel kit to the van roof, install it now before proceeding.
- Review vehicle manufacturer's roof mount recommendation.
- Perform the installation on a level surface.
- Always wear protective eyewear to keep debris out of your eyes when installing WEATHER GUARD® Van Products.
- Tighten all 5/16" hardware to 17 ft-lb when ready.
- Tighten all M6 & 1/4" hardware to 76 in-lb when ready.
- Warranty will be void if sealant is not applied to all seams and crevices.
- **This product is designed and intended for use on the standard 126" wheelbase Mercedes Metris as well as the extended 135" wheelbase Mercedes Metris.**

## OPERATION GUIDELINES

- Ladders transported on a vehicle should be properly supported and the overhang of the ladders beyond supporting points should be limited. Transporting a ladder with excessive overhang can result in reduced ladder life. Inspect your ladder before each use. Follow ANSI 14.2-2007 for direction on securing ladders to ladder racks.
- Load should be approximately centered front to rear and left to right on all vehicles. Failure to do this will cause damage to the rack and/or vehicle roof.
- Follow manufacturer's guidelines for maximum allowable roof load. **Do not overload the vehicle's roof.**
- It is the responsibility of the user to secure the load to the rack before transporting.
- Any modifications made to this product, or use of this product for any other purpose than its intended use, could create a hazardous condition that can cause serious personal injury or property damage.
- **At the end of the first week of use, check all of the fasteners for proper tightness and then check every three months thereafter.**
- For Vehicle Height Specifications with the rack installed, see page 9.

## HARDWARE KIT

DESCRIPTION	22002	22102
1/4" Lock Washer	8	4
1/4"-14 x 3/4" Self-Drilling Screw	6	-
5/16" Lock Washer	2	1
5/16" Washer	26	13
5/16"-18 Knob	2	1
5/16"-18 Nylon Lock Nut	10	5
5/16"-18 x 1-1/4" Carriage Bolt	8	4
5/16"-18 x 1-3/4" Carriage Bolt	8	4
5/16"-18 x 2-1/4" Carriage Bolt	2	1
3/8"-16 x 3/4" Thread-Cutting Screw	4	2
M6-1 x 40mm Bolt	-	4
M6-1 x 50mm Bolt	8	-
Mounting Plate	8	4
1/4" Spacer	4	-

## TOOLS REQUIRED

7/16" Wrench  
1/2" Wrench  
9/16" Wrench  
10mm Wrench  
Drill  
1/8" Drill Bit  
Measuring Tape or Ruler  
Painter's or Masking Tape  
Torque wrench

# PARTS LIST

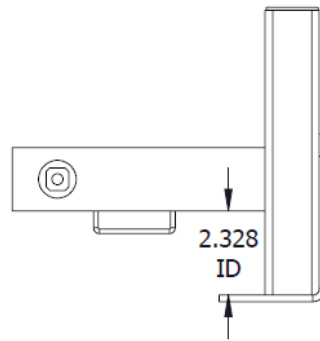

Center/Accessory Stand

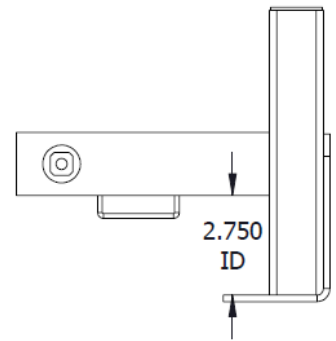

Front/Rear Stand

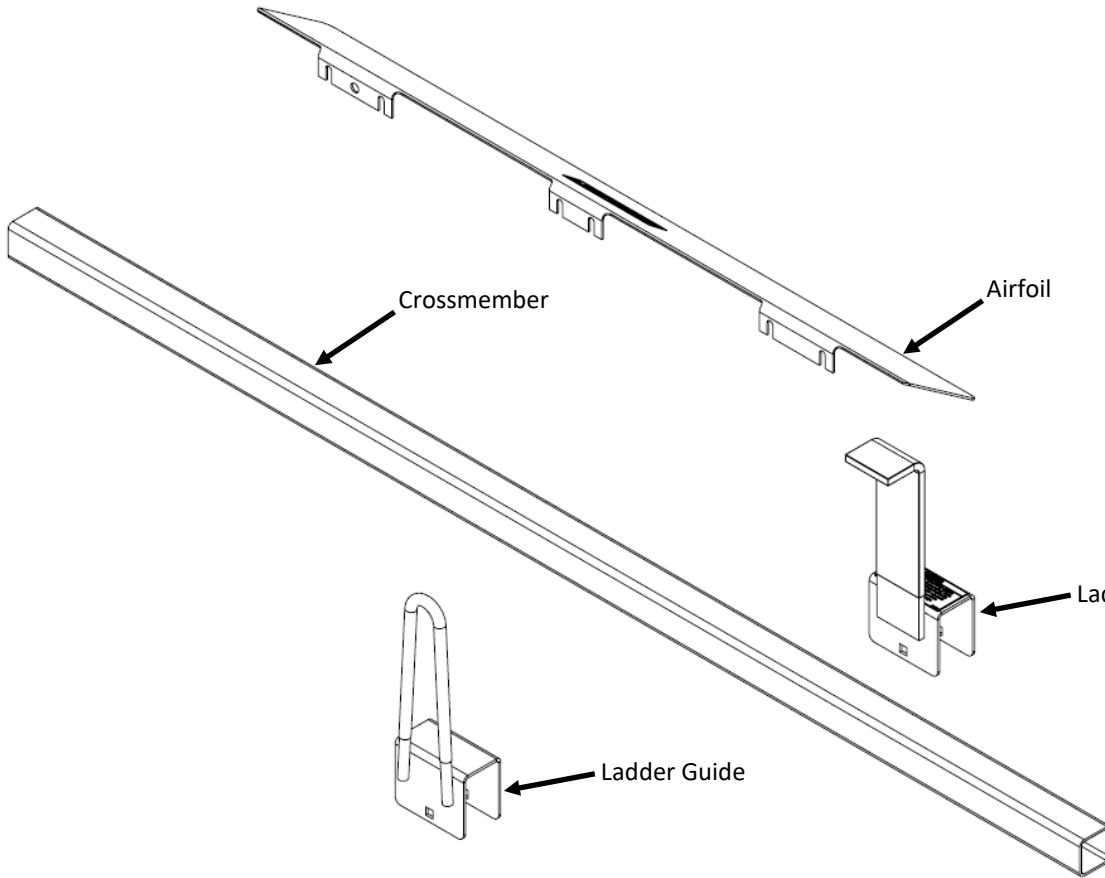

Crossmember

Airfoil

Ladder Stop

Ladder Guide

Stand

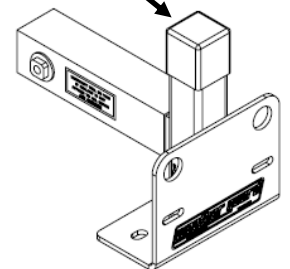

Rubber Shim

Rubber Spacer

DESCRIPTION	22002	22102
Stand - Front/Rear	4	-
Stand - Center	-	2
Crossmember	2	1
Rubber Spacer	4	2
Rubber Shim	4	-
Ladder Guide	1	1
Ladder Stop	1	-
Airfoil	1	-
*Sealant	1	1
*Velcro Strap	2	-
*Rubber Tape (70")	2	1

\*Item not shown

# CROSSMEMBER PREPARATION INSTRUCTIONS

## STEP 1. Mount Airfoil to front Crossmember

- Center Airfoil on a Crossmember tube as shown below and using it as a template, mark the centers of the open-ended slots (not the circular hole). Alternately, mark the tube at the corresponding dimensions shown below.
- Use a 1/8" drill bit to drill pilot holes through **one** side of the tube at the center of the tube face at each marked location.
- Drill a 1/4"-14 self-drilling screw into each hole, leaving a gap between the face of the tube and the head of the screw for the Airfoil to slip into.
- Apply a small amount of the provided Sealant at the face of the tube around each screw.
- Slip the Airfoil between the tube and the screws and use a wrench to tighten the screws.

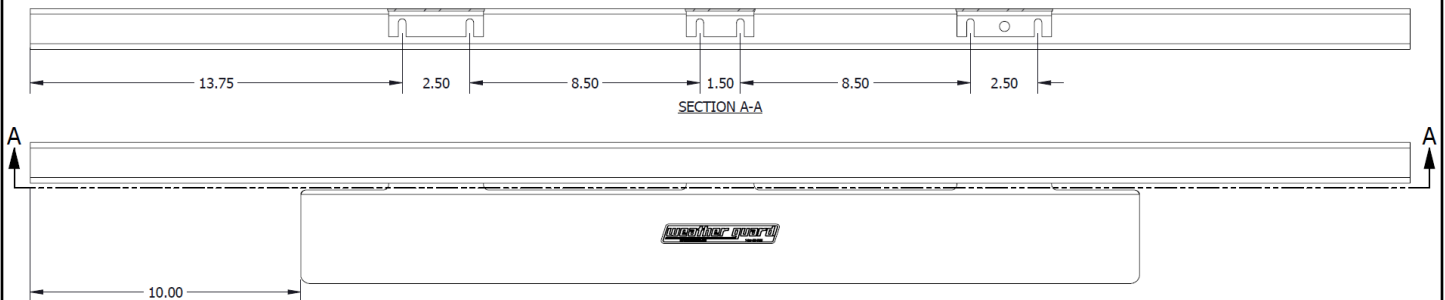

## STEP 2. Mark the Crossmember Width

- Use painter's or masking tape to mark the Stand overlap on each end of the Crossmembers as shown below. This will make it much easier to properly center the Crossmembers within the Stands later.
- Follow the table below to determine where to mark your Crossmembers. Be sure to measure to the outside edge of the tape, so that you are able to remove the tape later.
- Mark the tape with the word "Front" on the front Crossmember, "Center" on the center Crossmember, and "Rear" on the rear crossmember.

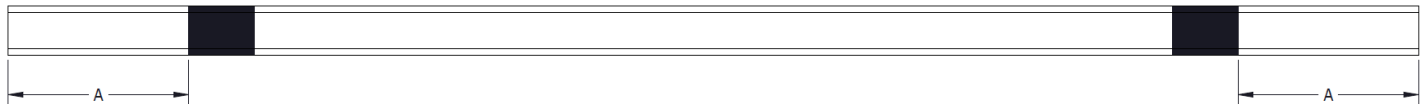

VEHICLE	TAPE DISTANCE		
	A		
	FRONT	CENTER	REAR
126" WB Mercedes Metris	6-1/8"	5-7/8"	5-5/8"
135" WB Mercedes Metris	6-1/8"	5-3/4"	5-5/8"



Proper taping of a rear Crossmember (5-5/8")

- For directly mounting to Mercedes Metris vans, proceed to page 5.
- For mounting to vans with Weather Guard Channels, proceed to page 7.

## DIRECT-MOUNT INSTALLATION INSTRUCTIONS

### STEP 1. Prepare Van Roof

- Remove the circular caps in van roof mounting points. (see page 10 diagrams if locations below are unclear)
  - If installing a 2-bar rack (22002), remove the rear 4 caps and the 2nd pairs of caps from the front.
  - If installing a 3-bar rack (22002 & 22102), remove the 12 rear-most caps.
  - If adding an accessory crossmember (22102), remove the 2nd pairs of caps from the rear.
  - Note: Do not use the front pairs of mounting holes.



- Apply the provided Sealant around the now-exposed mounting holes. Ensure roof surface is clean before applying the Sealant.
- Place the Rubber Spacers on the van roof with the holes aligned to the mounting holes in the van roof.



- Place the Rubber Shims on top of the front and rear Spacers with the thicker end of the Shim toward the outside of the van and centered on the Spacer.

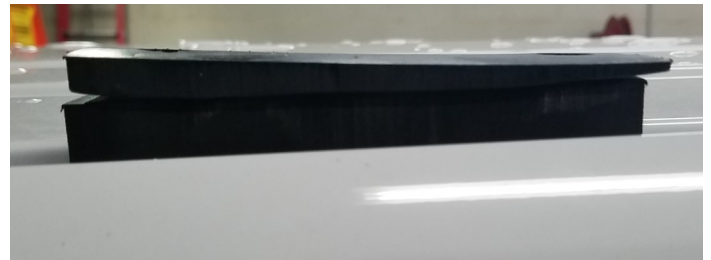



## DIRECT-MOUNT INSTALLATION INSTRUCTIONS (Continued)

### STEP 2. Install Half of the Stands

- Loosely install front and rear Stands atop the Rubber Shims on one side of the van using (2) M6 x 50mm bolts, (2) 1/4" lock washers, and (2) 5/16" washers through the outer slots in the base of the Stand. A 1/4" Spacer will be used on the thin end of the Shim.
  - Note:** If also installing a center/accessory crossmember, ensure that the lower Center Stands are only used at the location for the accessory crossmember (see Parts List on page 3). Loosely install Center Stand on the same side of the van using (2) M6 x 40 mm bolts, (2) 1/4" lock washers, and (2) 5/16" washers.
- Do not install the Stands on the other side of the van yet.**

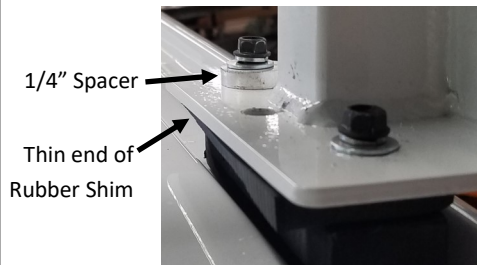

Install front & rear Stands using (2) M6 x 50 mm bolts, (2) 1/4" lock washers, and (2) 5/16" washers. A 1/4" Spacer will also be used between the stand and the flat washer on the thin end of the Shim.

Install Center Stand using (2) M6 x 40 mm bolts, (2) 1/4" lock washers, and (2) 5/16" washers.

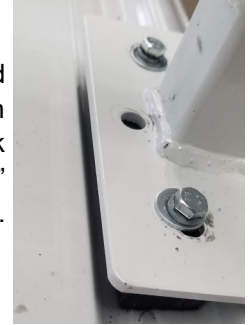

### STEP 3. Install Crossmember & Opposite Stand

- Insert a Crossmember into one of the previously-installed Stands. Note: The Airfoil is to be installed at the front of the van sloping downward.
- Place one of the remaining Stands over the remaining end of the Crossmember and loosely install it to the van roof using the same hardware used on the previous side of the van (see Step 2).
  - Note:** If also installing a center/accessory crossmember, ensure that the lower Center Stands are only used at the location for the accessory crossmember (see Parts List on page 3). Install to van roof using (2) M6 x 40 mm bolts, (2) 1/4" lock washers, and (2) 5/16" washers.
- Center the Crossmember between the two Stands using the tape applied earlier as a guide.
- Tighten the Crossmember in place within the Stands using a 3/8"-16 thread-cutting screw in the weldnut in the side of each Stand.
- Tighten the M6 bolts in the Stands.
- Remove the pieces of tape.
- Repeat this process for the remaining Crossmember(s) and then proceed to "Final Installation Instructions" on page 8.



## WG CHANNEL-MOUNT INSTALLATION INSTRUCTIONS

### STEP 1. Assemble & Place Mounting Plates

- Determine the rough locations where you would like your Crossmembers placed within the channels.
- Decide if you are using the two slots (recommended) in the Stands or the center hole.
  - If using the slots, assemble and insert two mounting plates per Stand as shown below.
  - If using the center hole, assemble and insert one mounting plate per Stand as shown below.
- When inserting the Mounting Plates into the channels at the desired locations, keep in mind that they will not be able to slide past the heads of the bolts that hold the channels to the roof.

Insert a 5/16"-18 x 1-1/4" carriage bolt into each Mounting Plate with the word "TOP" facing the threads.



Insert the Mounting Plates and carriage bolts into the channels near the desired Crossmember locations.



Rotate the Mounting Plates 90° clockwise.

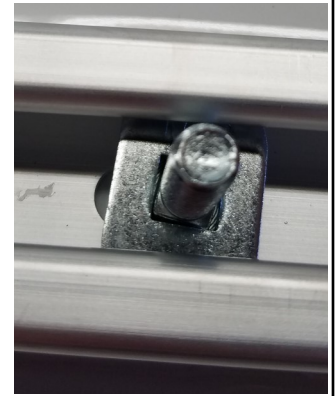

### STEP 2. Install Half of the Stands (left picture below)

- Loosely install Stands on one side of the van using a 5/16" washer and 5/16"-18 nylon lock nut per mounting plate. **Do not install the Stands on the other side of the van yet.** Note: It may also be necessary to place a Rubber Shim beneath the front and rear Stands to level out the Crossmembers.

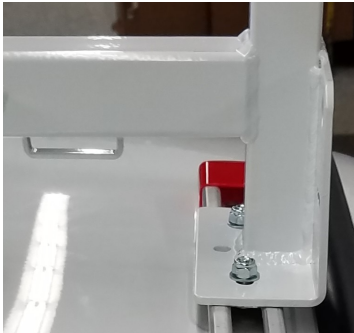

### STEP 3. Install Crossmember & Opposite Stand (right picture above)

- Insert a Crossmember into one of the previously-installed Stands. Note: The Airfoil is to be installed at the front of the van sloping downward.
- Place one of the remaining Stands over the remaining end of the Crossmember and loosely install it to the channel with a 5/16" washer and 5/16"-18 nylon lock nut per mounting plate. Note: It may also be necessary to place a Rubber Shim beneath the front and rear Stands to level out the Crossmembers.
- Center the Crossmember between the two Stands using the tape applied earlier as a guide.
- Tighten the Crossmember in place within the stands using a 3/8"-16 thread-cutting screw in the weldnut in the side of each Stand.
- Finalize the desired location of the Crossmember and tighten the nuts on the Stands.
- Remove the pieces of tape.
- Repeat this process for the remaining Crossmember(s)

## FINAL INSTALLATION INSTRUCTIONS

### STEP 1. Apply Sealant

- Apply provided Sealant around the 3/8"-16 thread-cutting screws in the Stands.
- Apply provided Sealant around the Crossmembers where they meet the Stands.

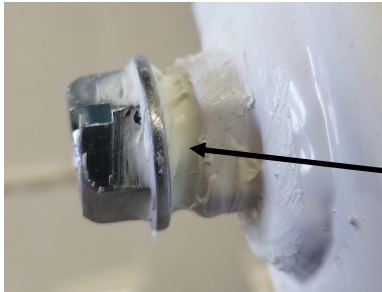

Seal These  
Crevices  
All Around

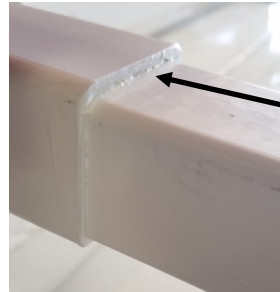

Seal These  
Joints All  
Around

### STEP 2. Apply Rubber Tape

- Cut two 6-3/4" pieces from each strip of Rubber Tape. Apply these pieces to the top of the crosspost of each Stand.
- Measure the distance on the Crossmember between the two Stand crossposts and cut a piece of Rubber Tape accordingly. Apply the piece of Rubber Tape to the top of the Crossmember. Repeat for remaining Crossmember(s).
- **Note: Ensure the tops of the crossposts and Crossmembers are clean before applying the Rubber Tape.**



### STEP 3. Install Ladder Stop and Ladder Guide(s)

- Slip the Ladder Stop/Guide over the top of the Crossmember.
- Use a 5/16"-18 x 2-1/4" carriage bolt, 5/16" washer, and Knob to clamp the Stop/Guide in place in the location you desire. The Knob will allow you to adjust its position or remove it by hand later.
  - A lock washer is also provided in case the knob wants to loosen by itself over time.
  - Alternately, a 5/16"-18 nylon lock nut (provided) can be used in place of the Knob for a more permanent placement.

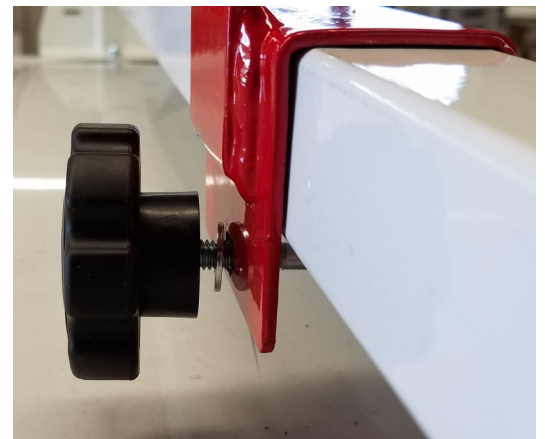

### STEP 4. Attach Velcro Straps through the Stand loops



## VEHICLE HEIGHT SPECIFICATIONS

### Overall Vehicle Height Information

- The table below shows the overall height of a given vehicle with the rack installed.
- The values in the table are based on stock, unmodified suspension of an unloaded vehicle.
- The first column in the table shows the overall height if any and all ladder guides and ladder stops are removed and nothing is loaded above the top of the vertical posts of the Stands (“A” in diagram below).
- The second column in the table shows the overall height if a ladder guide or ladder stop is the highest point on the vehicle (“B” in diagram below).
- The third column in the table shows the overall height if any and all ladder guides and ladder stops are removed and a ladder of 5-7/8” thickness is loaded on the rack (“C” in diagram below).

OVERALL VEHICLE HEIGHT			
Van	Rack Only (A)	w/Guide or Stop (B)	w/Ladder & No Guides or Stops (C)
126” WB Metris	82-7/8”	86-1/4”	85-3/8”
135” WB Metris	83”	86-3/8”	85.5”

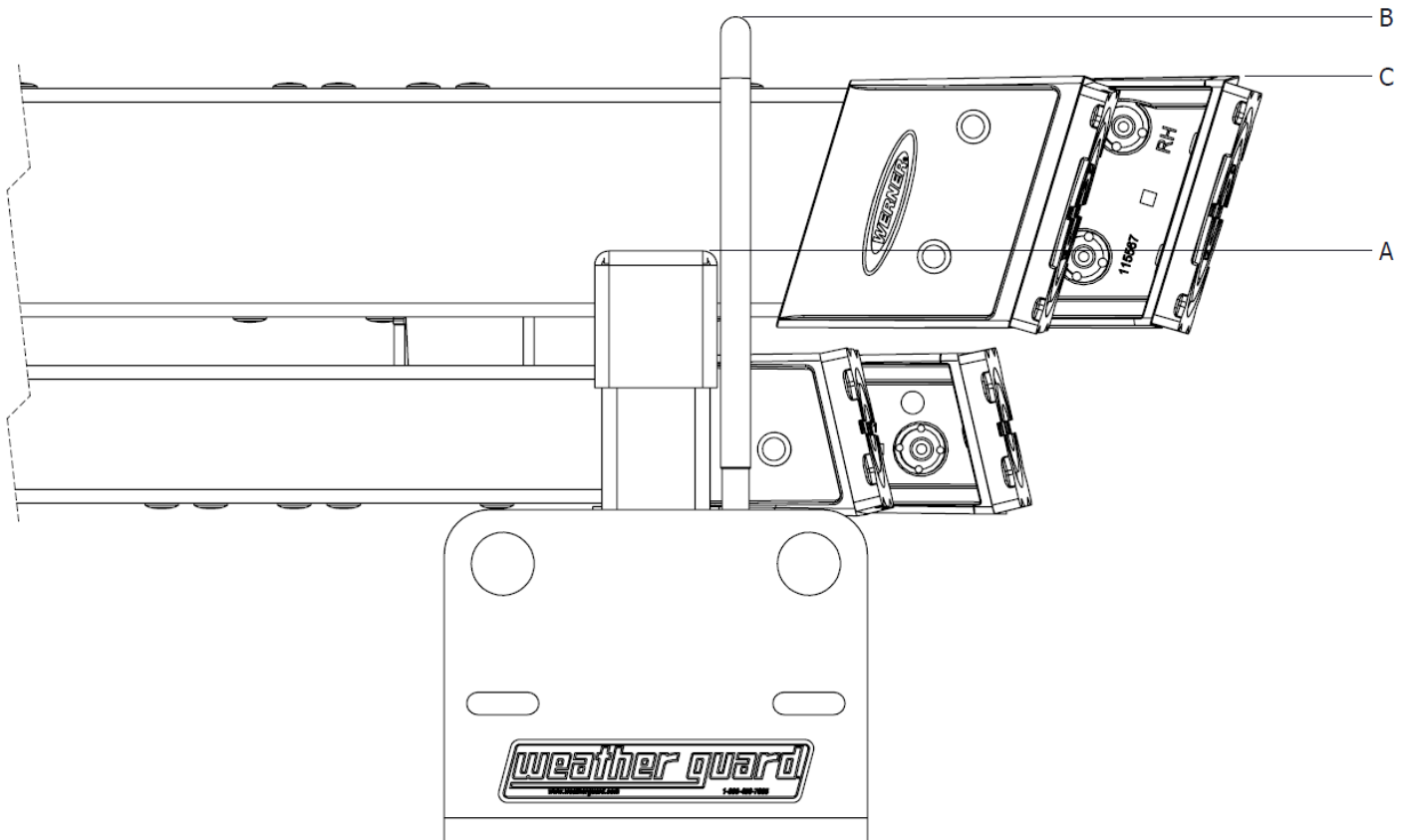

## ROOF MOUNTING POINT REFERENCE DIAGRAMS

Shown with Rear of van to the right. All dimensions are for reference only and may vary slightly.

**X**—Do not use the front mounting points

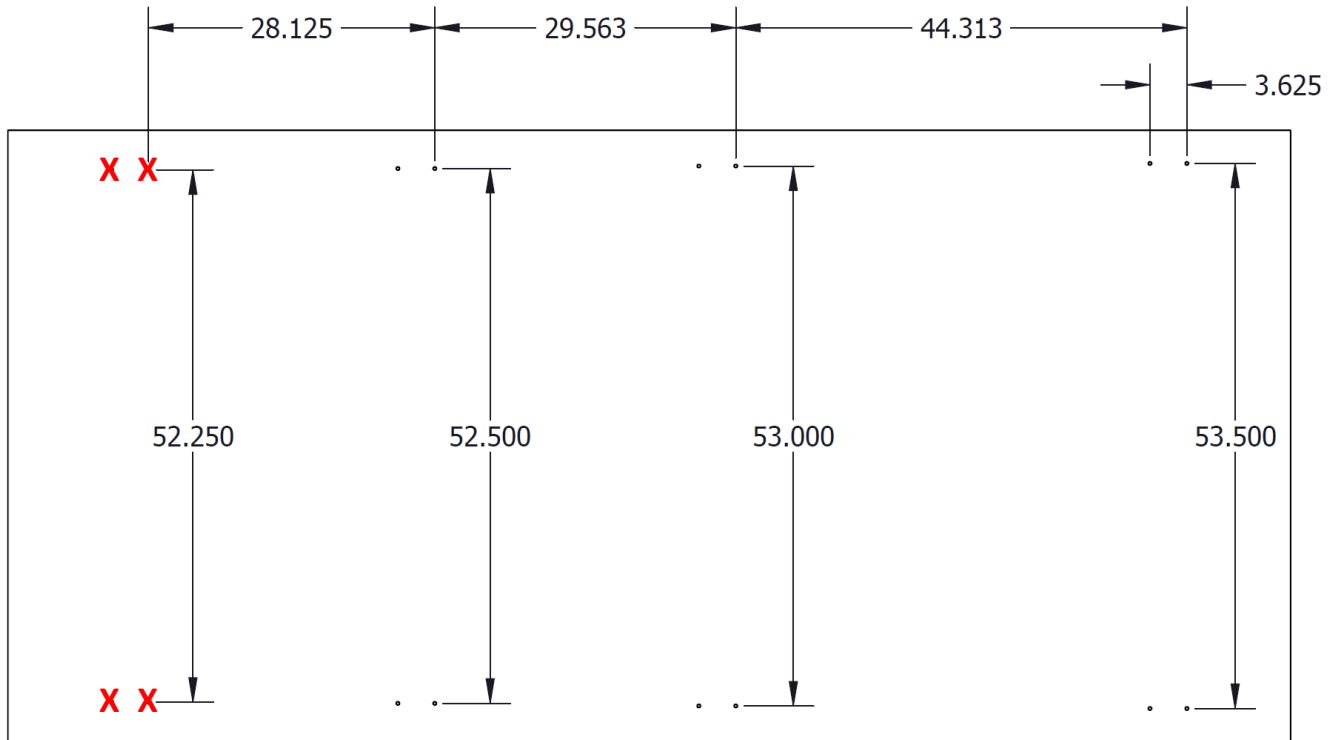

126" Wheelbase Mercedes Metris

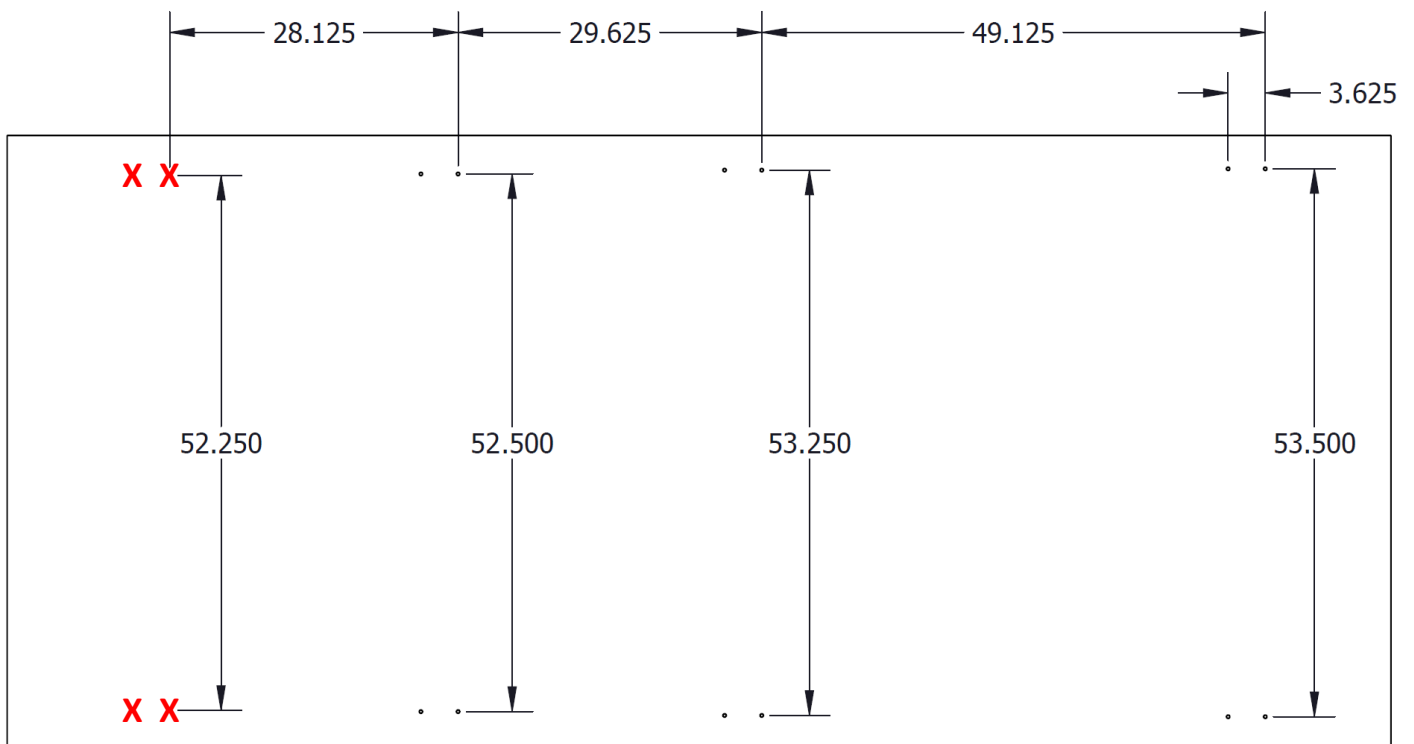

135" Wheelbase Mercedes Metris

**! WARNING**

This product can reduce the driver's ability to clearly see roadways, vehicular or pedestrian traffic and other objects through the rear and side windows of the vehicle, which can cause an accident. Extra precautions should be taken when driving a vehicle with this product. Make all adjustments necessary to ensure maximum visibility, including but not limited to, changing mirror and seating positions. State and local laws may prohibit obstruction of windows in a moving vehicle.

These instructions are to be followed using the parts and fasteners supplied for proper installation. Any modifications or improper installation of this product will create a hazardous condition that could result in death, serious personal injury and/or property damage.

**! CAUTION**

Prior to drilling, so as not to cut electric wires, fuel lines, brake lines, etc., check behind and underneath drilling and mounting locations. To keep debris out of your eyes when checking the underside of the vehicle, or when drilling, always wear protective eye wear. Failure to heed this warning will result in death or serious injury.

**- NOTICE -**

Any modification or unintended use of this product shall immediately void all manufacturer's warranties. Manufacturer disclaims all liability for injuries to persons or property resulting from any modification to, or unintended use of this product.

**WERNER CO. LIMITED LIFETIME WARRANTY FOR WEATHER GUARD® PRODUCTS**

**WEATHER GUARD® Products — Limited Lifetime Warranty (Purchased on or after 1/1/2009)**

WERNER CO. (the "Manufacturer") warrants to the original purchaser only that WEATHER GUARD® Truck and Van Products (the "WEATHER GUARD® Product") will be free from defects in material and workmanship from the date of purchase and continuing for the expected lifetime of the WEATHER GUARD® Product. A copy of the original sales receipt must be supplied to the Manufacturer at the time a warranty claim is made. This warranty terminates if the original purchaser transfers the WEATHER GUARD® Product to any other person.

**What is Covered**

All WEATHER GUARD® Products identified above that are purchased on or after January 1, 2009.

**What We Will Do to Correct Problems**

Subject to the limitations and exclusions described in this limited warranty, the Manufacturer will remedy defects in materials or workmanship by providing one of the following remedies at its option and without charge to the original purchaser for parts or labor: (a) repairing the defective portion of the WEATHER GUARD® Product or (b) replacing the entire WEATHER GUARD® Product. In addition, the manufacturer may elect at its option, not to repair or replace the WEATHER GUARD® Product, but rather issue to the original purchaser a refund equal to the purchase price paid for the WEATHER GUARD® Product or a credit to be used toward the purchase of new WEATHER GUARD® Product.

**What is Not Covered**

This limited warranty expressly excludes:

- Defects caused by normal wear and tear, cosmetic rust, scratches, accidents, unlawful vehicle operation, or modification to the product, or any types or repair of a WEATHER GUARD® Product other than those authorized or provided by the Manufacturer.
- Defects resulting from conditions beyond the Manufacturer's control including, but not limited to misuse, overloading, or failure to assemble, mount or use the WEATHER GUARD® Product in accordance with the Manufacturer's written instructions or guidelines included with the WEATHER GUARD® Product or made available to the original purchaser.
- Damage to the contents of the box or vehicle.
- TO THE EXTENT PERMITTED BY LAW, IN NO EVENT SHALL THE MANUFACTURER BE LIABLE FOR ANY INCIDENTAL, SPECIAL, INDIRECT, OR CONSEQUENTIAL DAMAGES, INCLUDING ANY ECONOMIC LOSS, WHETHER RESULTING FROM NON-PERFORMANCE, USE, MISUSE OR INABILITY TO USE THE WEATHER GUARD® PRODUCT OR THE MANUFACTURER'S NEGLIGENCE.

**No Other Express Warranty Applies**

This Limited Lifetime Warranty is the sole and exclusive warranty for WEATHER GUARD® Products. No employee, agent, dealer, or other person is authorized to alter this warranty or make any other warranty on behalf of WERNER CO.

**Notification Procedures**

If the WEATHER GUARD® Product does not conform with the terms of this limited warranty, the original owner must promptly notify the Manufacturer in writing upon discovery of the nonconformity. In order to receive the remedies under this limited warranty, the warranty claim must describe the nature of the nonconformity, and a copy of the original sales receipt, invoice, bill or other proof of purchase must accompany the claim. Repairs or modifications made to the WEATHER GUARD® Product by other than the Manufacturer or its authorized agent will nullify this limited warranty. Coverage under this limited warranty is conditioned at all times upon the owner's compliance with these required notification and repair procedures. Warranty claims must include reciprocal contact information and may be made via certified mail to:

**WERNER CO. ATTN: Warranty Claims**

420 E. Terra Cotta Avenue Crystal Lake, IL 60014

**If you have any questions, please call toll free at 1-800-456-7865.**

©2018 WERNER CO.

